

---

**MINISTRY OF ENVIRONMENT, LANDS AND PARKS**

**BROAD ECOSYSTEM INVENTORY DATABASE**

**SYSTEM REQUIREMENTS**

**Version 1.0**

**21 March 1997**

---

**MINISTRY OF ENVIRONMENT, LANDS AND PARKS**

**BROAD ECOSYSTEM INVENTORY DATABASE**

**SYSTEM REQUIREMENTS**

**Version 1.0**

**21 March 1997**

Prepared by : Coopers & Lybrand Consulting

4th Floor, 777 Broughton Street

Victoria, British Columbia

Canada, V8W 1E3

Telephone: (250) 360-5421

Fax: (250) 360-5400

---

## TABLE OF CONTENTS

<b>A. HIGH LEVEL REQUIREMENTS</b>	<b>5</b>
<b>A.1. Introduction</b>	<b>5</b>
<b>A.2. Project Outline</b>	<b>5</b>
A.2.1. Project Goals	5
A.2.2. Project Objectives	6
A.2.3. Project Scope	6
A.2.4. Project Context	7
<b>A.3. Business FUNCTION HIERARCHY Model</b>	<b>7</b>
<b>A.4. BUSINESS Process Model</b>	<b>9</b>
<b>A.5. Business Function OVERVIEWS</b>	<b>13</b>
A.5.1. Maintain Organism Taxa (MNGTAXA)	13
A.5.2. Maintain Ecological Classifications (MNGECOREF).	15
A.5.3. Manage Project (MNGPRJ)	18
A.5.4. Manage BEI	19
A.5.5. Use BEI Data (MNGQRY)	23
<b>A.6. Other Technical Requirements</b>	<b>26</b>
A.6.1. Data Warehouse Requirements	26
A.6.2. System Connectivity	28
A.6.3. Security and Control Requirements	28
A.6.4. Performance Requirements	29
A.6.5. Volume/space Requirements	29
A.6.6. Technical Strategy	30
<b>A.7. Other Non -Technical requirements</b>	<b>32</b>
<b>A.8. SIGN OFF</b>	<b>33</b>
<b>B. APPENDICES</b>	<b>34</b>
<b>B.1. Function Descriptions</b>	<b>34</b>
B.1.1. Manage Organism Taxa	34
B.1.2. Maintain Ecological Classes (MNGECOREF)	43
B.1.3. Maintain Projects (MNGPROJ)	52
B.1.4. Manage BEI	62
B.1.5. Use BEI Data	96
<b>B.2. Disconnected Data Capture</b>	<b>104</b>
<b>B.3. BEI Technical Standards Document</b>	<b>105</b>
B.3.1. High-Level Specifications	105
<b>B.4. Glossary of Terms</b>	<b>108</b>
<b>B.5. BEI Data Model</b>	<b>112</b>

<b>B.6.</b>	<b>BEI Entity and Attribute Descriptions</b>	<b>112</b>
<b>B.7.</b>	<b>OUTSTANDING BEI BUSINESS ISSUES</b>	<b>112</b>

## **A. HIGH LEVEL REQUIREMENTS**

### **A.1. INTRODUCTION**

The Resources Inventory and Data Management Branch of The Ministry of Environment, Lands and Parks (MELP) defines, manages and monitors British Columbia's wildlife habitat and populations. Their information is of interest to many agencies and industries including the Ministry of Forests.

The Broad Ecosystem Inventory (BEI) project goals are to support regional land use planning by providing a seamless 1:250,000 scale standardized digital coverage of the province's ecosystem. The framework defined here, will form the basis for future Resources Inventory and Data Management Branch field data management projects. The scope of the Broad Ecosystem Inventory (BEI) project focuses on Broad Ecosystem Information (BEI) business requirements.

This document describes the BEI business requirements in detail including baseline definition, disconnected data capture processes and interpretation standards. It also documents the preliminary design of the automated processes and data base for the BEI system.

This document provides the framework for the next phase of the project, Detailed Design of the BEI system. Design components such as the logical data model, entity and attribute descriptions are included in the appendices for reference purposes. Any additional design components, such as domain descriptions, the function-to-data mapping (i.e. Create, Read, Update, Delete matrix (CRUD)), will be provided during Design. Outstanding questions noted in the requirements will also be resolved during the Detailed Design phase.

### **A.2. PROJECT OUTLINE**

#### **A.2.1. Project Goals**

The goal of the BEI is to:

- support provincial and regional land use planning by providing seamless standardized electronic coverage of the province's ecosystem, that is, a coverage not bound by artificial boundaries such as project or mapsheet. A seamless coverage can be used to:
  1. depict the geographic distribution of the province's broad ecosystems;
  2. produce standard format 1:250,000 interpretative capability/suitability maps for wildlife species of regional and provincial significance; and
  3. enable production of new types of interpretations by overlaying or combining other polygons with the Biogeoclimatic Ecosystem Classification (BEC) polygons, and
- improve data management efficiency and reduce the impact the large number of data requests on headquarters office.

### A.2.2. Project Objectives

The objectives of BEI are to achieve seamless standardized data access. The project must:

- build a database for mapping broad ecosystem unit attribute data;
- automate and streamline remote data capture by contractors;
- develop a detailed spatial standards document for contractors;
- develop an effective seamless linkage between spatial and non-spatial data ; and
- improve efficiency and minimize impact of requests providing Ministry personnel, other ministries and the public with direct access to BEI data through the Ministry data warehouse.

### A.2.3. Project Scope

The following diagram, Figure 1, defines the scope and components of this project.

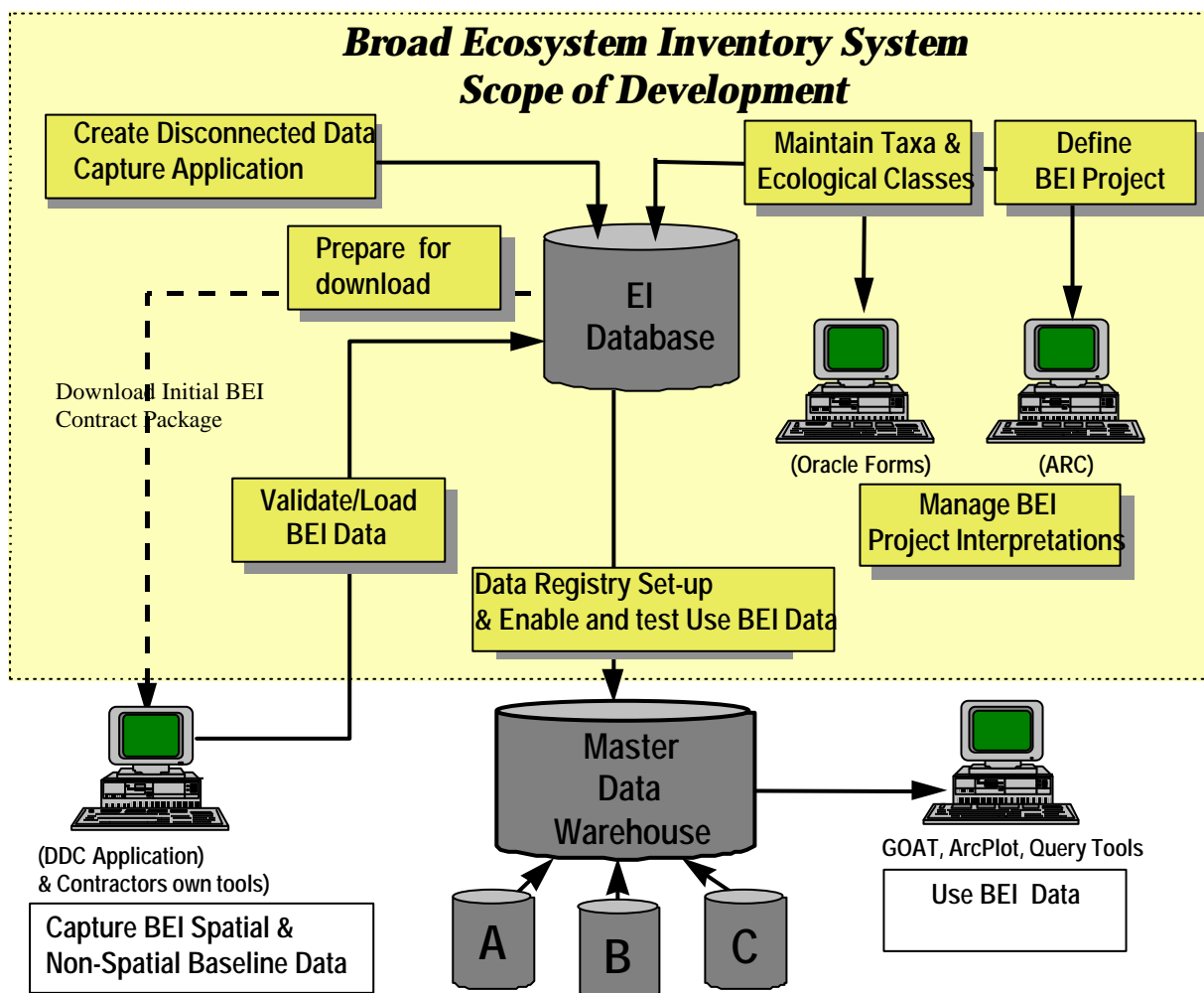

Figure 1. Project Scope Diagram

### A.2.4. Project Context

The BEI system accepts information from a number of external agencies. Products of the BEI are supplied back to a number of client categories and agencies. The context diagram below illustrates the relationship between the BEI system and its external stakeholders defined by this exchange of products and information.

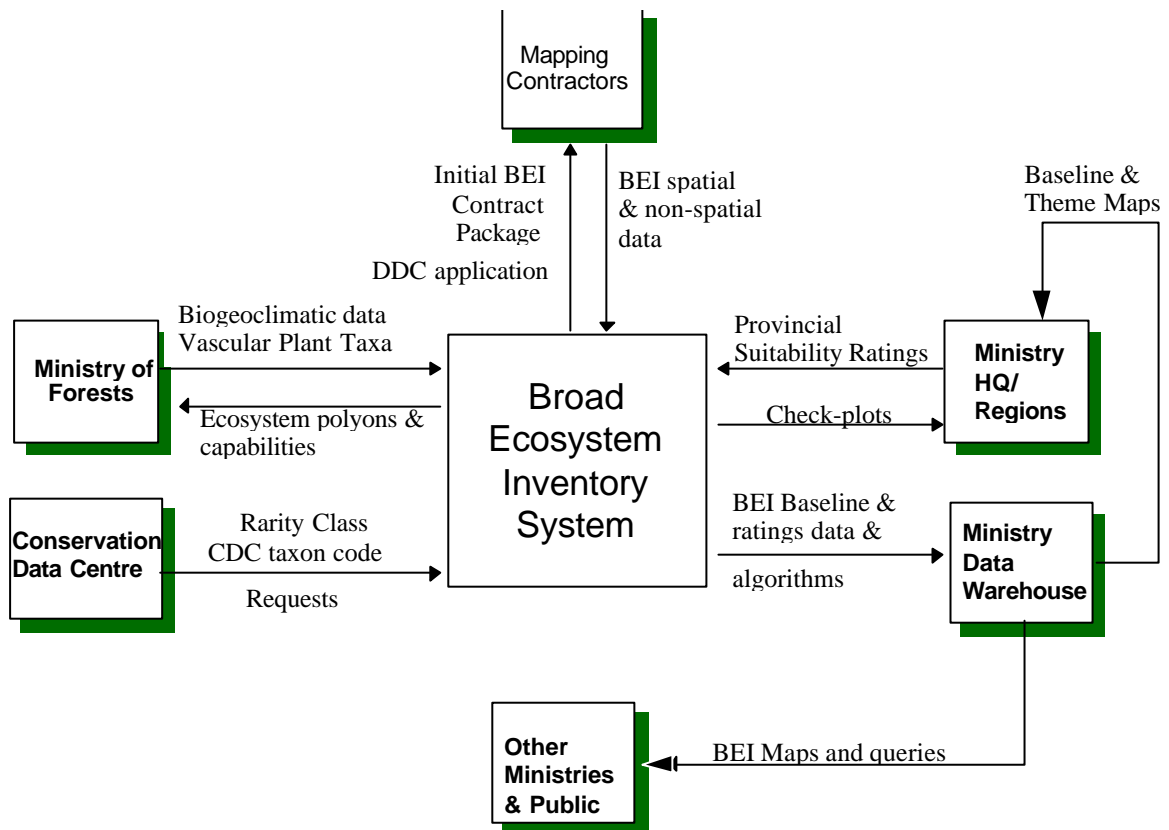

Figure 2. Project Context Diagram

### A.3. BUSINESS FUNCTION HIERARCHY MODEL

The two diagrams that follow define the business functions within the scope of the Broad

Ecosystem Inventory. It does not show the sequence of the functions or the data that functions use.

**Business Function Model (Part 1)**

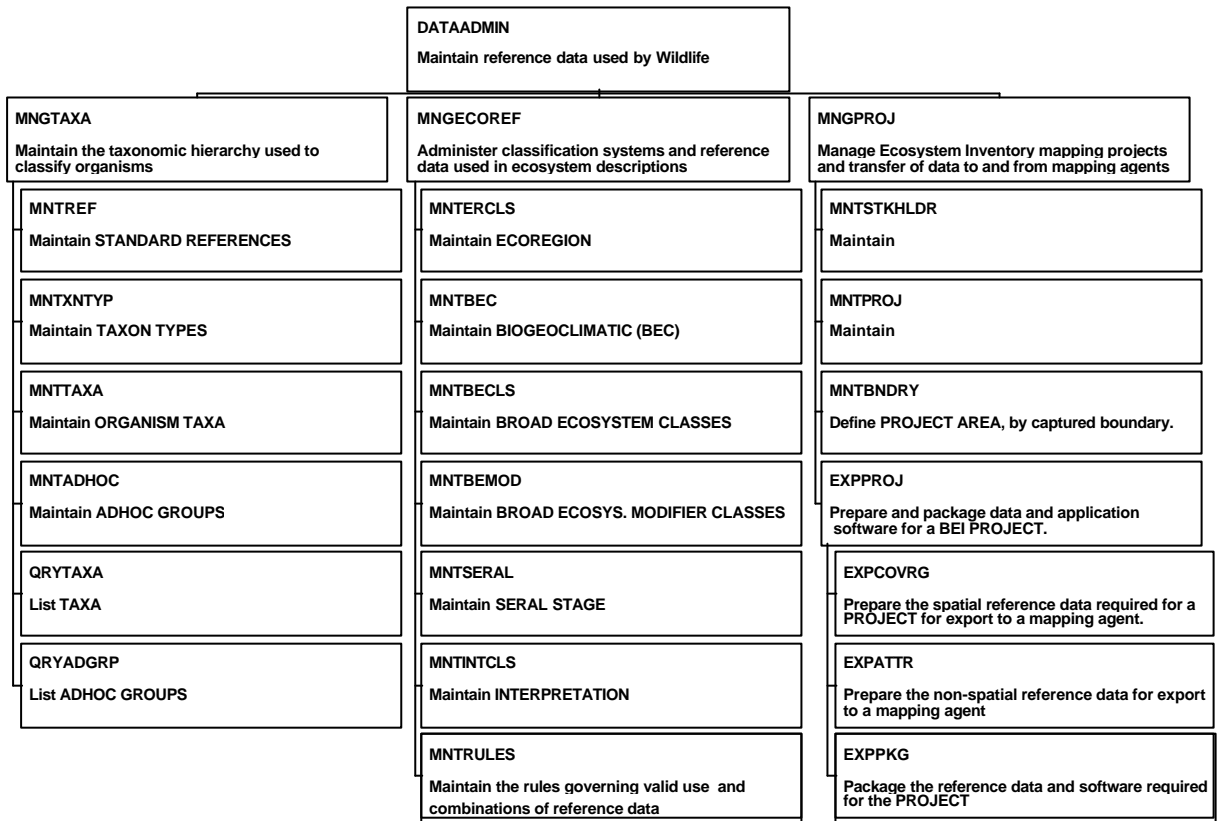

**Business Function Model (Part 2)**

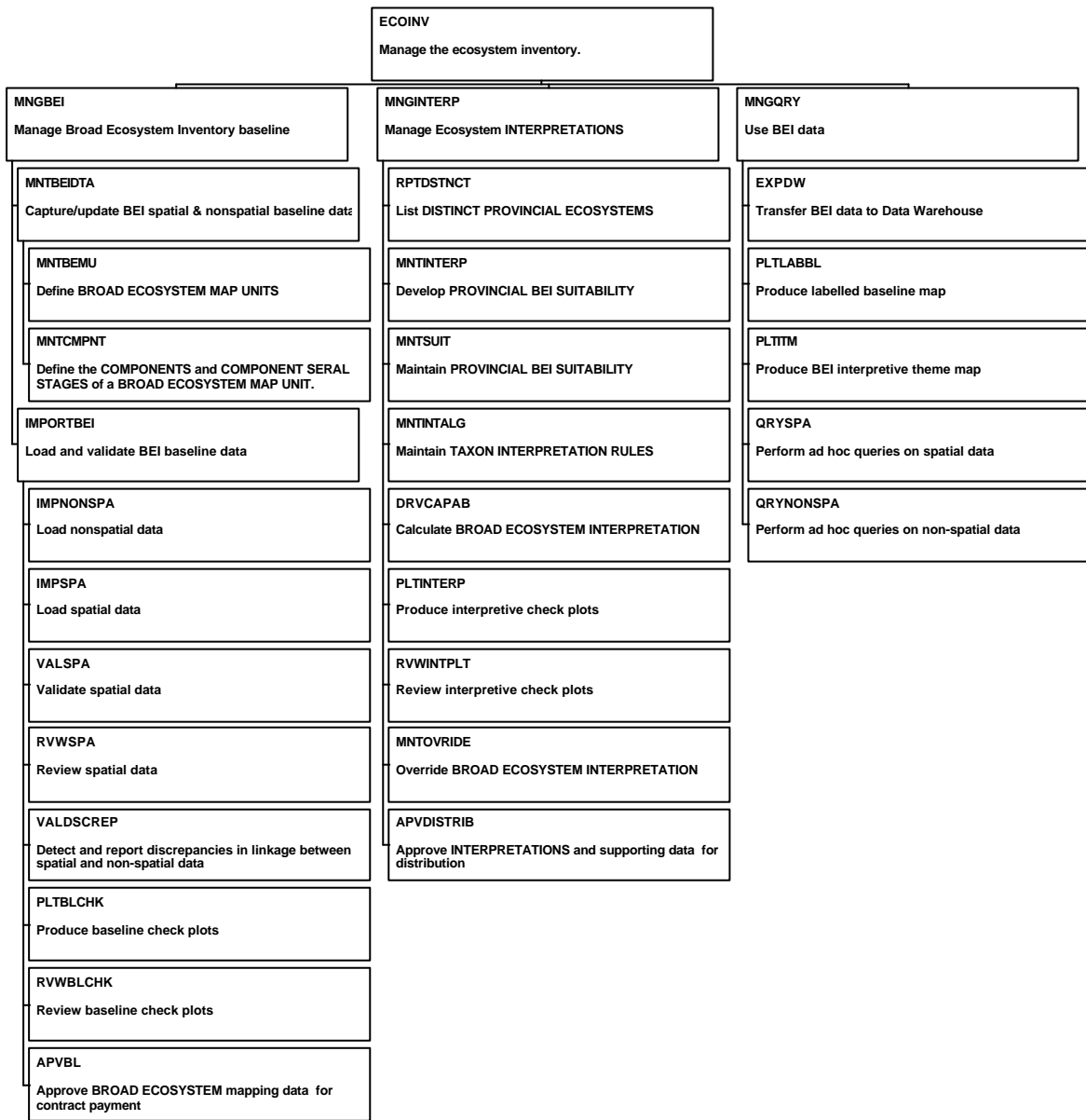

NOTE: MNTBEU and MNTCMPNT may be implemented as one function.

Figure 3. Business Function Model

**A.4. BUSINESS PROCESS MODEL**

The purpose of the business process model is to show:

- the sequence of steps taken to produce a product or service. Each step is also a business function on the preceding business hierarchy model;
- the organization, person or role the function is performed by; and
- the events that initiate a function and its outcomes.

The following models represent the sequence of steps or business functions required to obtain the broad ecosystem inventory data. The first diagram presents an overview. The diagrams that follow show each step in more detail.

### BROAD ECOSYSTEM INVENTORY (BEI) SYSTEM Manage BEI Data

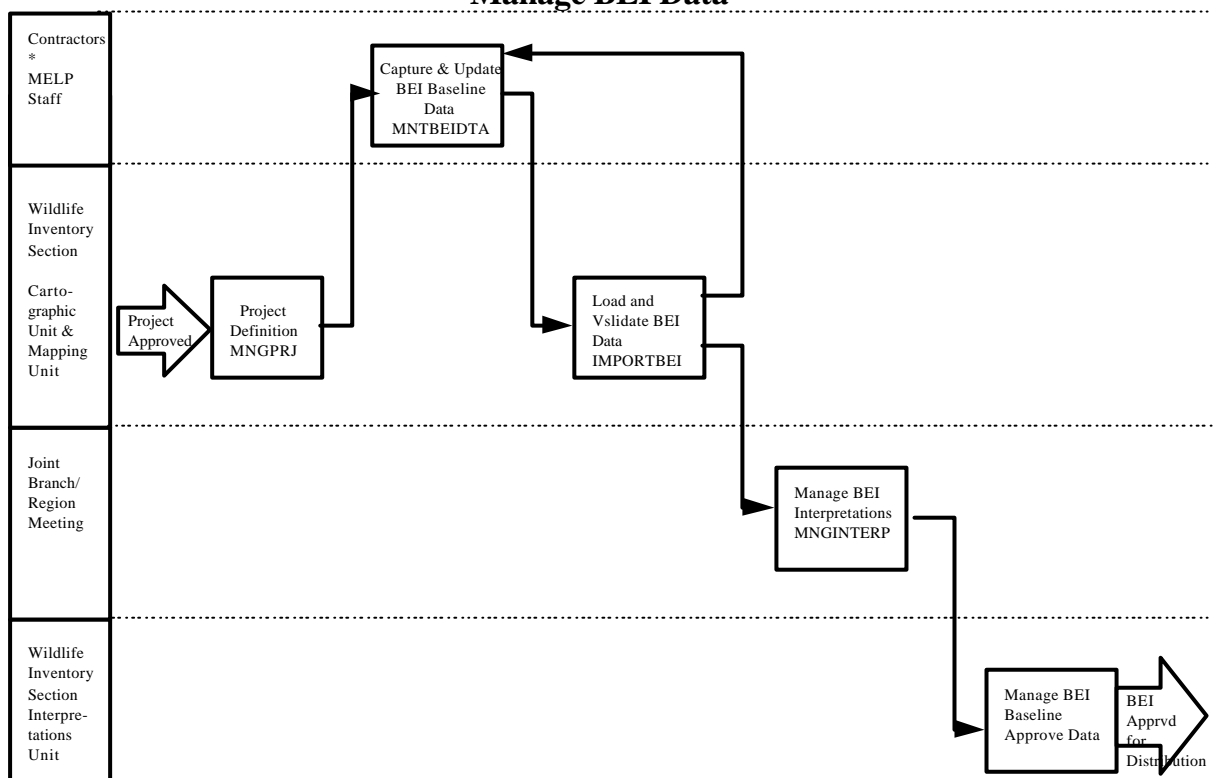

**BROAD ECOSYSTEM INVENTORY (BEI) SYSTEM**

**Maintain Projects**

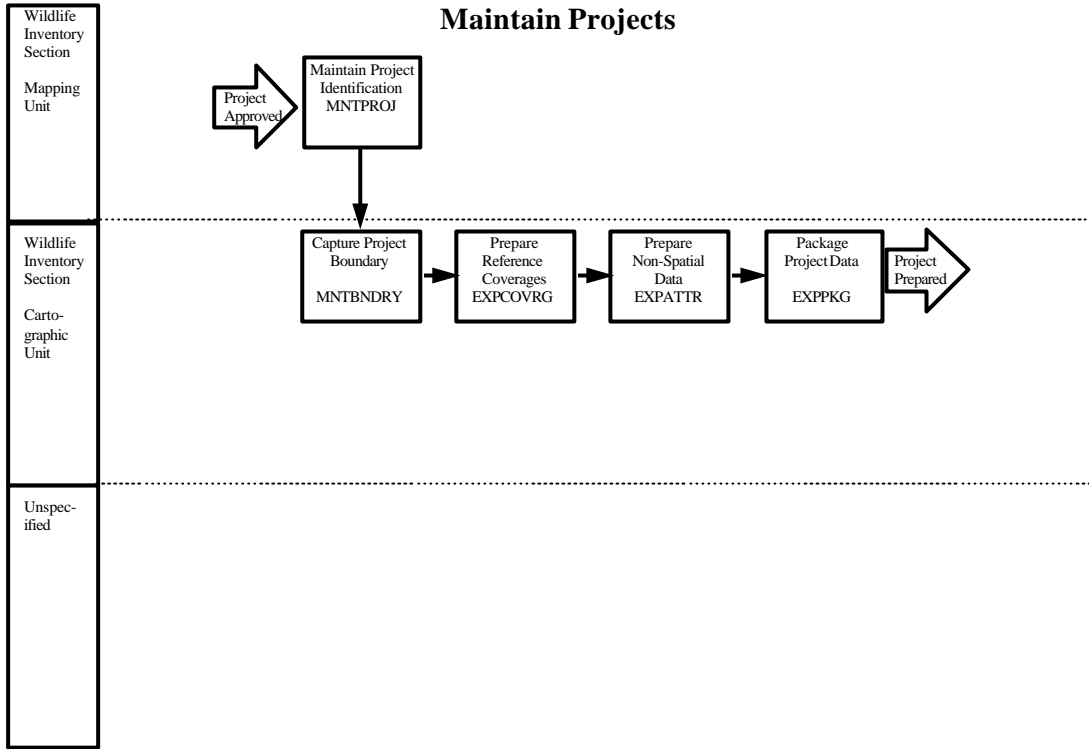

**BROAD ECOSYSTEM INVENTORY (BEI) SYSTEM**

**Manage BEI Baseline (Data Capture)**

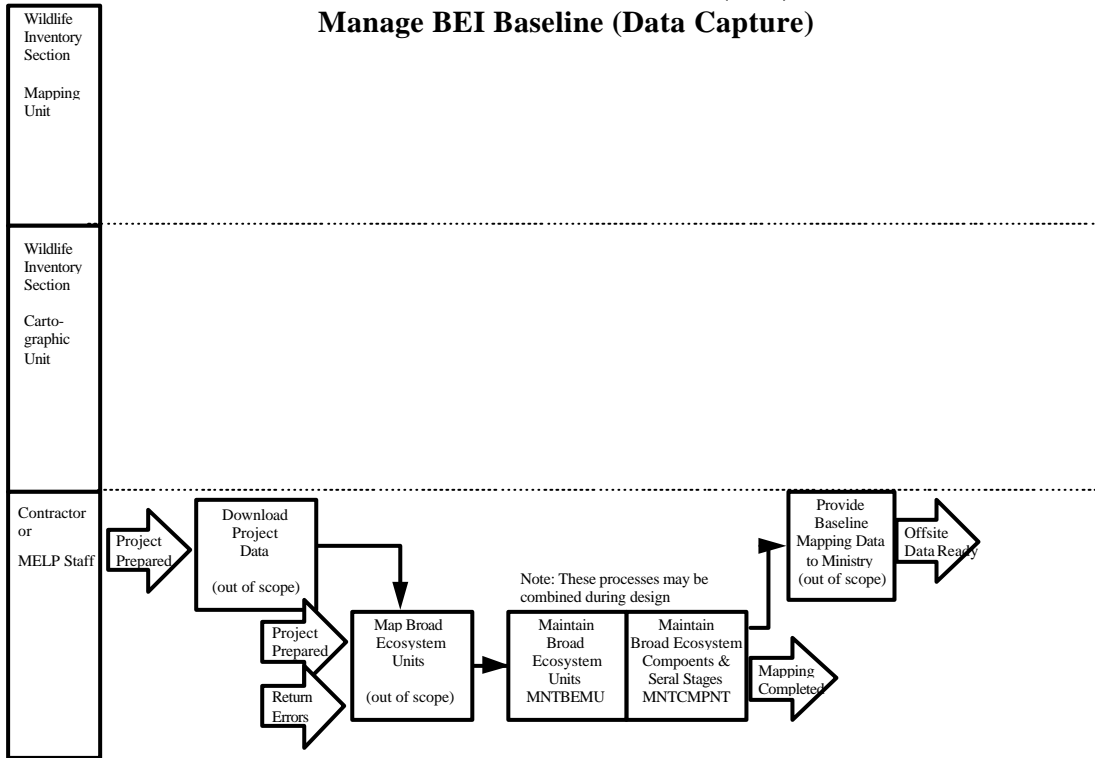

**BROAD ECOSYSTEM INVENTORY (BEI) SYSTEM  
Load and Validate BEI Baseline Data (IMPORTBEI)**

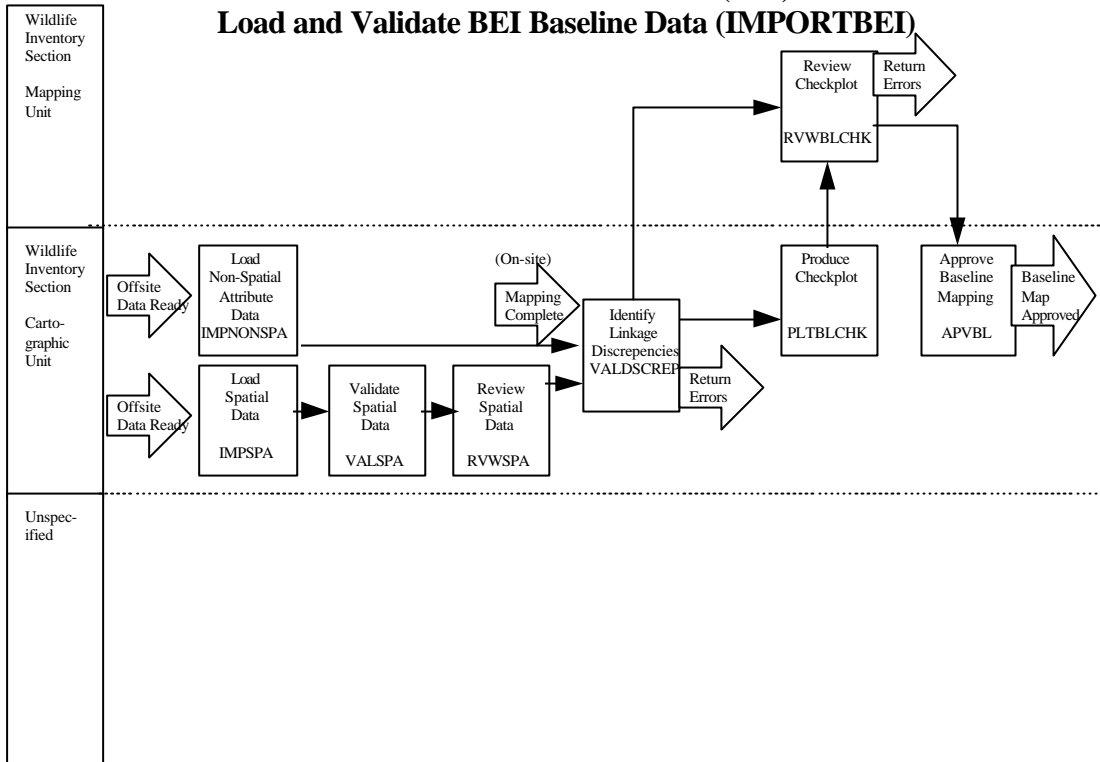

**BROAD ECOSYSTEM INVENTORY (BEI) SYSTEM  
Manage BEI Interpretations (MNGINTERP)**

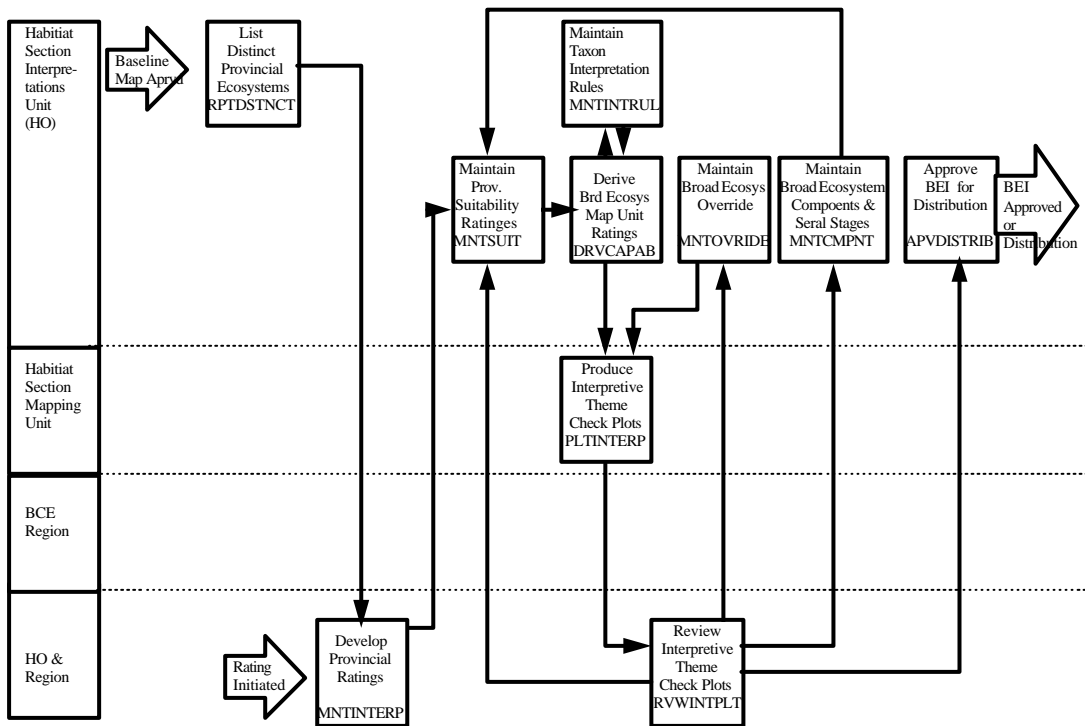

## **A.5. BUSINESS FUNCTION OVERVIEWS**

### **A.5.1. Maintain Organism Taxa (MNGTAXA)**

#### *A.5.1.1 Business Context*

*Purpose:*

- Document the taxonomic classifications used to identify organisms in the province;
- Record the reference(s) that are the authorities for tax used; and
- Record selected changes to the taxonomy.

*Needed to support:*

- Wildlife observations;
- Ecosystem interpretations; and
- identifying the status of species.

*Stakeholders:*

- Ministry of Environment Regions.
- Resources Inventory and Data Management Branch.
- Resource Inventory Committee.
- Royal BC Museum.
- Ministry of Forests.
- Species inventory contractors.
- Universities.

***A.1.1.1.***

**A.5.1.2 Function Requirements**

*Maintain ORGANISM TAXON (MNTTAXA):* Maintain organism taxonomy and the classification of organisms according to their presumed natural relationship, i.e. the TAXON SYNONYMS and TAXON REFERENCES.

Maintain ADHOC GROUPS (MNTADHOC): *Maintain a list of valid groupings other than taxa. Examples include old growth species, benthic organisms etc..*

*Maintain STANDARD REFERENCES (MNTREF):* Maintain the standard reference for a taxonomy or life form group. A standard reference is a published standard for a taxonomic rank or life form group membership and includes the person, team or organisation responsible for setting the standard

*Maintain TAXON TYPES (MNTXNTYP):* Maintain a list of the taxon levels such as Order, Family and Genus in the taxonomic hierarchy.

*Report Taxa (QRYTAXA):* Report taxon by kingdom or taxon type.

*Report Adhoc Groups (QRYADGRP) Report on taxa by a classification group other than taxa.*

**A.5.1.3 History Requirements**

- On ORGANISM TAXON to accommodate observations where taxa cannot be re-assigned.

**A.5.1.4 Future Considerations**

- to maintain other taxa must allow for growth of the data base up to 100,000;
- automated interface with BC Museum or Forests taxon data bases; and
- automated interface with CDC's Biophysical Conservation Database (BCD).

**A.5.2. Maintain Ecological Classifications (MNGECOREF).****A.5.2.1 Business Context**

*Purpose:*

- identify the various ecological land classifications that are used to describe both broad and detailed ecosystem units and terrestrial ecosystem sites on the ground; and
- document wildlife interpretations types, and rating classification schemes.

*Needed to support:*

- description of the ecological areas and sites;
- establishment of suitability ratings by Broad Ecosystem Inventory classes that can be used to classify areas of the province by their wildlife suitability and capability; and
- production of theme maps.

*Stakeholders:*

- Resources Inventory and Data Mgmt. Branch (Wildlife Section);
- Ministry Regions;
- Ministry of Forests; and
- Mapping contractors.

**A.5.2.2. Function Requirements**

*Maintain ECOREGION CLASSES (MNTERCLS):* Maintain a list of Ecoregion classes. The Ecoregion classification system stratifies British Columbia's terrestrial and marine ecosystem complexity into discrete geographical units at five levels: Ecodomains and Ecodivisions, Ecoprovinces, Ecoregions and Ecosections.

*Maintain BIOGEOCLIMATIC CLASSES (MNTBEC):* Maintain a list of the Biogeoclimatic Classes. It integrates climate, vegetation and site classifications at a broad landscape level. The classification is a hierarchical system. There are four levels: zone, subzone, variant and phase.

*Maintain BROAD ECOSYSTEM CLASSES : (MNTBECLS):* Maintain the list of broad ecosystem classes used to describe a geographic area in terms of the distinct dominant vegetative cover and non-vegetative cover (such as lakes or rock outcrops) it supports.

*Maintain BROAD ECOSYSTEM CLASS MODIFIERS (MNTBEMOD):* Maintain the list of broad ecosystem class modifiers. The modifiers are used to refine the classification of a broad ecosystem based on site specific characteristics.

*Maintain SERAL STAGE CLASSES (MNTSERAL):* Maintain the list of seral stage classes. Seral stage is a named stage in general transition from a non-vegetated pioneer state to an over-mature forested climax state.

*Maintain INTERPRETATION CLASSES (MNTINTCLS):* Maintain the classes within an interpretation scheme used to rank broad ecosystems for wildlife.

*Maintain Class Rules (MNTRULES):* Maintain the rules governing valid use and combinations of class codes.

**A.5.2.3 History Requirements:** versions of Ecoregion classification and biogeoclimatic classification.

**A.5.2.4 Future Considerations:** interfaces to MOF, Conservation Data Centre, Species Inventory, etc..

### **A.5.3. Manage Project (MNGPRJ)**

#### **A.5.3.1. Business Context**

*Purpose:*

- maintain a list of projects and document the scope of study. This includes the type of project, project boundary, taxa and type of evaluation being conducted.

*Needed to support:*

- collection and capture of BEI spatial and non-spatial data.

*Stakeholders:*

- resources Inventory and Data Management Branch Wildlife Inventory Section; and
- mapping contractors.

#### **A.5.3.2. Function Requirements**

*Maintain Project Identification (MNTPROJ):* Maintain the information necessary to identify a project.

*Capture Project Boundary (MNTBNDRY):* Capture the project boundary to depict the geographic area within scope of the project.

*Prepare Project Reference Coverages (EXPCOVRG):* Convert the BEC, Ecosections, NTS Water bodies and Project boundary coverages into the export format prescribed by the technical standards.

*Prepare Project Non-Spatial Data (EXPATTR):* Select and convert the non-spatial attribute data the mapping contractors require to capture and validate the area being mapped. The data is captured for export in the format prescribed by the branch technical standards.

*Package Project Data (EXPPKG):* Package all the information necessary for the project into a form that is easily downloaded by the mapping contractor.

#### **A.5.3.3 History Requirements**

- none identified

#### **A.5.3.4 Future Considerations**

- extend to other projects such as Detailed Ecosystem Inventory (DEI) and Species Inventory (SPI) projects.

## **A.5.4. Manage BEI**

### ***A.5.4.1 Business Context***

*Purpose*

- capture and validate BEI data;
- assign wildlife interpretations; and
- approve the distribution of BEI data.

*Needed to support:*

- rating of Provincial Broad Ecosystem Classes & Broad Ecosystem Polygons;  
and
- interpretation and theme mapping.

*Stakeholders:*

- Resources Inventory and Data Management Branch Habitat Section:
- Quality Assurance Unit,
- BCE Region,
- Mapping contractors.

#### **A.5.4.2. Function Requirements**

##### **Manage BEI Baseline**

**Maintain Broad Ecosystem Map Units (MNTBEMU):** Enter and maintain the broad ecosystem mapping unit. The data will usually be captured off-site but may be created and updated internally.

**Maintain BROAD ECOSYSTEM COMPONENTS and BROAD ECOSYSTEM SERIAL STAGES (MNTCMPNT):** Capture and maintain the broad ecosystem mapping unit component and its serial stages.

**Load & Validate Project Non-Spatial Data (IMPNONSPA):** Capture the data, provided by the mapping contractor, from an external source into the Test data base.

**Load Spatial Data (IMPSPA):** Load the Broad Ecosystem Coverage created by the mapping contractor. This process assumes there is no reason to up-load the BEC or Ecoregion coverages since the business rules state they cannot be changed. The broad ecosystem coverage will be overlaid with the clipped BEC and Ecoregion coverages retained by the Ministry that were used for the project.

**Validate Project Spatial Data (VALSPA):** Validate the Broad Ecosystem Coverage to ensure it is topologically clean, the datum, projection, precision and tolerance are correct, all tags are unique to project coverage, feature codes are valid and there are no slivers.

**Review Project Spatial Data (RVWSPA):** Visually review the spatial data uploaded from the contractor. The review is conducted to confirm sliver errors and completeness of the ecosystem, Ecoregion etc. If the errors are minor the Ministry may correct them, rather than return the data to the contractor. If the data is incorrect an error message file will be returned to the contractor and the incorrect data package dropped.

**Identify Linkage Discrepancies (VALDSCREP):** Detect discrepancies between related spatial and non-spatial data elements.

**Produce Check Plots (PLTBLCHK):** Plot a labelled broad ecosystem unit map for the specified area. The map may be plotted either to the screen or to a plotter for subsequent review. This process is usually performed by the BEI mapping contractor, but on occasion will be done in-house.

**Review Check Plots (RVWBLCHK):** Conduct a scientific review of the baseline check-plots for errors (ref. RFP page 8). The check-plots are compared back to source map: broad ecosystem, Ecoregion, biogeoclimatic.

**Approve Baseline Mapping (APVBL):** If the submitted map file passes both the automated validation and scientific review processes, the baseline mapping data is approved for payment by the project manager. The approved project baseline mapping data replaces the a previous "production" version.

**Manage BEI Interpretations(MNGINTERP)**

*List PROVINCIAL BROAD ECOSYSTEMS (RPTDSTNCT):* List the distinct broad ecosystems (unique combinations of Ecosection, BEC, Broad Ecosystem Class, Broad Ecosystem Class Modifier).

*Develop Rating Benchmarks (OUT OF SCOPE):* Develop interpretative ratings through a meeting and joint discussion of branch and regional biologists. For each species being rated, a provincial benchmark for the highest rating is established. Regional biologists also identify a benchmark for their region. (This is currently not a formal process). During the joint session biologists establish ratings for each broad ecosystem unit seral stage, relative to the benchmark. The ratings are based on the characteristics of the broad ecosystem unit and those bordering it.

*Maintain PROVINCIAL BEI SUITABILITYS (MNTINTERP):* Maintain the suitability rating for taxon agreed upon by the joint headquarters/regional meeting for PROVINCIAL BROAD ECOSYSTEMS by seral stage and season.

*Derive FEATURE INTERPRETATION (MNTSUIT):* Derive suitability ratings for the Broad Ecosystem Map Units based on the interpretation algorithm assigned to a particular taxa.

*Produce Interpretative Check Plots (PLTINTERP):* Plot the capability or suitability interpretative maps as a means of checking the assigned provincial ratings, polygon-specific ratings, and to some extent the original classification of the broad ecosystem units.

*Review Interpretative Check Plots (RVWINTPLT):* Review the interpretative check-plots by branch and region biologists.

*Maintain Broad Ecosystem Interpretation Overrides (MNTOVERRIDE):* Enter an over-ride interpretative rating for the broad ecosystem map unit. This is done only when the provincial rating is not appropriate for a particular unit.

*Approve the Ecosystem Interpretations data for distribution.*

**A.5.4.3. History Requirements**

- on BROAD ECOSYSTEM SERAL STAGES, BROAD FEATURE INTERPRETATIONS

**A.5.4.4. Future Considerations**

- how to update seral stages of a polygon.

## **A.5.5. Use BEI Data (MNGQRY)**

### ***A.5.5.1. Business Context***

*Purpose:*

- provide direct ministry wide access to the BEI data required to produce BEI maps and answer adhoc queries.

*Needed to support:*

- depiction of geographic distribution of the province's ecosystem; and
- evaluation of habitat for wildlife management and land use planning.

*Stakeholders:*

- Resources Inventory and Data Management Branch Wildlife Inventory Section:
  - Strategic Information Unit
  - Quality Assurance Unit
  
- BCE Region,
- Public, other Branches & Ministries.

***A.1.1.1.***

***A.5.5.2.Function Requirements***

Populate the Data Registry to enable the following:

- Produce draft and presentation quality labelled BEI Baseline Maps;
- Produce draft and presentation quality interpretation theme maps;
- Perform adhoc BEI spatial queries; and
- Perform adhoc BEI non-spatial data queries.

***A.5.5.3.History Requirements:***

- Require at least 20 years of historical data for time series studies, although details prior to the most recent 5 year period can be summarized and archived from the system.

***A.5.5.4.Access Requirements:***

- Ministry access via GIS and Oracle Access Tool (GOAT)/ArcView;
- Other agency access via File Transfer Protocol (FTP) files;
- PC access (Oracle ODBC to GIS); and
- UNIX access (Custom ARC/SQL code).

***A.5.5.5.Future Considerations:***

- Remote data entry and query;
- Public access via the World-wide Web (WWW);
- Contractors to move to generalized Topographic Resource Information Mangement system (TRIM);
- A template builder for creating look-up tables.

## A.6. OTHER TECHNICAL REQUIREMENTS

### A.6.1. Data Warehouse Requirements

The data warehouse theory is to integrate data across time and subject into a central repository, while separating production processing from the data analysis and reporting functions. To achieve this, live data is periodically (based on the business schedule for that data category) extracted from the production tables. It is then organized by application with physical links replaced by logical links, initially transformed and loaded into the data warehouse. This allows the warehouse to be organized by subject, rather than by application.

In this Requirements phase we have determined the Resources Inventory and Data Management Branch business needs and the BEI data to be included in the corporate data warehouse. The two tier homogeneous architecture will include a single host server system for the data warehouse with client workstations which will run the front-end decision support and analysis tools. Metadata will be employed to govern the collection, transformation and presentation format of BEI data.

The data warehouse will be designed for extensive growth and change. The warehouse tables will initially be loaded with a full copy, (bulk download), of existing BEI production data. The only major changes to existing data will be to optimize and transform the data to a standard BEI warehouse format, and add date columns to indicate data currency and history. Future data will not require transformation as it is being fed directly from the Disconnect Data Capture (DDC) application. Once the warehouse has been created, test queries will be run during acceptance testing to gain an understanding of performance. The Ministry will need to define standard queries for testing purposes. Data will not immediately be included from other sources e.g.. MoF databases.

Spatial data will be stored in ARC workspaces. These workspaces will be timestamped (i.e. updated spatial data coverages will be stored in a newly dated workspace). The Spatial/Non-spatial link will determine which historical mapping workspace is to be used.

For performance purposes, warehouse table columns that are related will be physically adjacent, while columns with many null values, or long values will be right-most in a table. Also all table keys will be on the left-most columns.

Warehouse data will be read-only, meaning security will not allow changes to be made directly on the data. All warehouse updates will follow the process where data changes are made in, and transferred into the warehouse from, production environments only. On a regularly scheduled basis, depending on the volatility and time dependency of the data, a copy of the production database will be copied using the Oracle Copy facility to the warehouse server (see Figure 4 following).

When network and server loads are low, this file will be loaded into the warehouse via SQL\*Loader, or possibly Oracle Open Gateway, with a data load validation report produced. Data completeness (i.e. mandatory fields) can be tested during the load process while referential integrity will be tested, following the load, by a standard test

query.

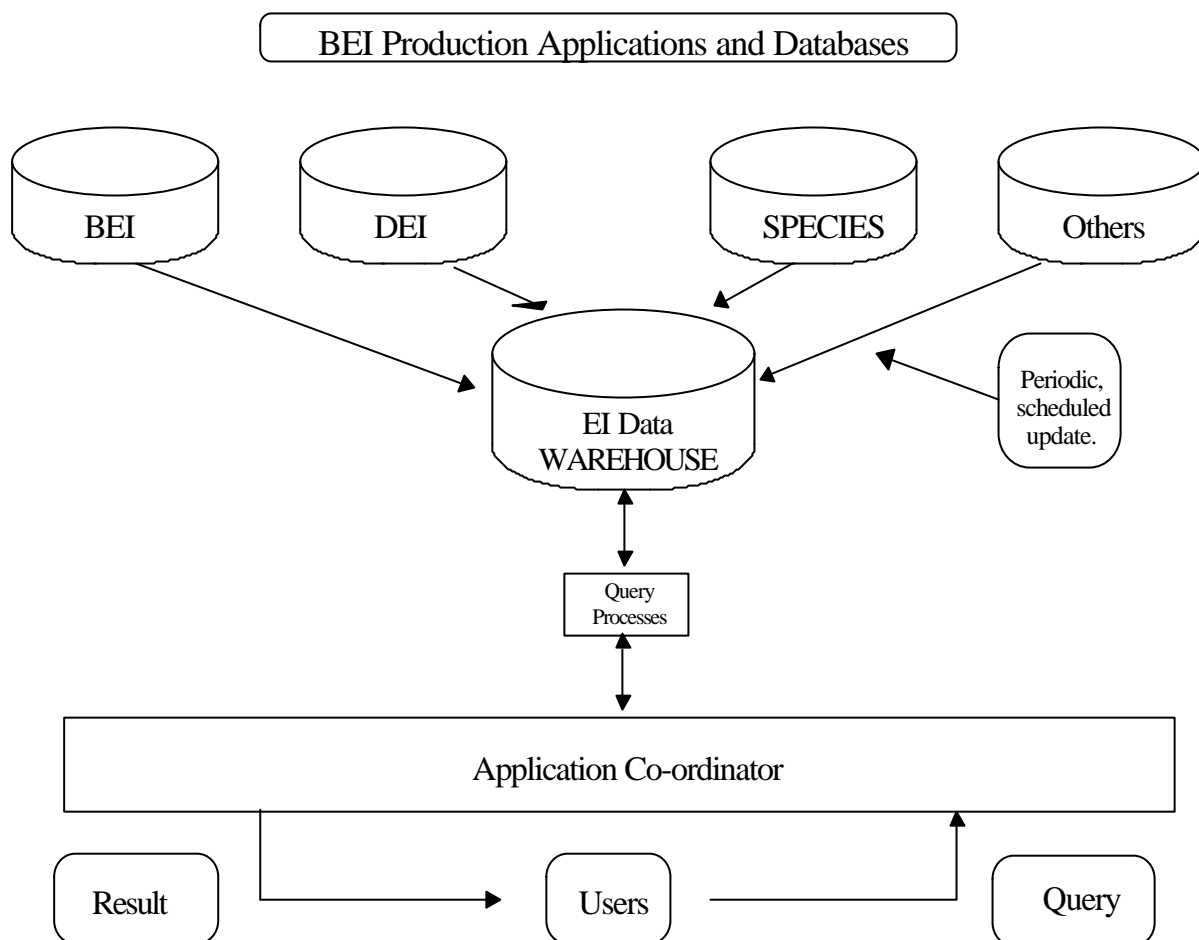

Figure 4. High-level BEI Data Warehouse Conceptual Diagram

Open Data-Base Connectivity (ODBC) will be used to connect desktop client applications to the data warehouse by a standard means. This means any tool that supports ANSI standard SQL directly, or via a gateway, can utilize the warehouse data. This allows spatial, personal and distributed database, web, graphic, reporting, images, local or remote custom application, transaction processing, and potentially analytical tools, to access and utilize the data from the warehouse in a standard format.

The design phase, using Oracle7 Designer/2000, will define how to synchronize, standardize, ensure integrity of, normalize, and secure the data. During the design phase the inputs, outputs, integration schedule, transformation edits, table and view formats, and metadata will be defined. The metadata will map the business language

to a data dictionary, define context and tables, elements, indexes, keys, ranges and delivery mechanism.

Multi-dimensional-analysis (multiple BEI product analysis) will not be used at this point for time/series dependent analysis. The Branch may want to restructure its data in the future to include data set change metrics, e.g. rating for a habitat as it changes over time. On-Line Analytical Processing (OLAP) tools will then become relevant allowing predefined and adhoc interactive personal dataviews. This BEI design will not focus on these plans but will remain open for inclusion in the future.

### **A.6.2. System Connectivity**

The following data interfaces will be needed by the BEI application:

- Detailed Ecosystem Inventory data
- Species Inventory (SPI) data;
- Ministry Data Warehouse through the Data Registry;
- Sensitive Species data;
- Ministry of Forest BEC classifications; and
- common registry of stakeholders (e.g. mapping contractors, survey contractors).

### **A.6.3. Security and Control Requirements**

There are no special security requirements for BEI data itself although links to remote databases, (i.e. sensitive species) may require additional controls. Following are the general techniques used to address confidentiality, criticality and availability requirements. The System Design Specifications will identify the extent to which these will be implemented.

#### ***A.6.3.1. Access controls (these are not specifically requested requirements):***

- access control for Oracle and ARC data and functions based on roles: Public, Data Administrator and Data Correlator, (this will be expanded in the System Design Specifications document);
- provide System level access based on UNIX Groups in combination with unique Ministry standard userids;
- the maximum number of login attempts permitted set at five;
- a defined notification process for departing, department changing, employees;
- an automatic Userid expiration period of 90 days set for unused accounts;
- a standard procedures/authorization forms for requesting/recording accounts;
- timeout set at 30 minutes for inactive sessions;
- provide users with good security practise awareness bulletins i.e. no password sharing; and
- provide monitoring of unauthorized access attempts, local and dial-up, as applicable.

#### ***A.6.3.2. Data integrity controls (these are not specifically requested requirements):***

- document all application development standards and methodology;

- create isolated Development, Test and Production environments;
- provide data validity and reasonableness checks at regular process intervals including data entry;
- backup all programs that are to be upgraded to a new version;
- require sign-off for code migration into production;
- monitor changes to highly sensitive data;
- ensure backups are fully tested;
- segregation of critical functions with cross-knowledge training; and
- ensure change requests receive formal authorization.

#### ***A.6.3.3. Availability controls (these are not specifically requested requirements):***

- server should reside in a restricted environment;
- physical access to server should be restricted to an authorized few;
- fully tested backups should be stored off-site;
- a secondary server should be available in case of disaster to the primary server and a tested recovery procedure should be in place;
- procedures, processes, policies, full configuration should be documented to ensure cross knowledge is maintained within the Branch;
- a secondary method of transferring data to remote offices should be defined; and
- battery backup should be in place on all servers.

### **A.6.4. Performance Requirements**

The BEI application needs to meet a minimum performance level:

- batch download files must be less than 50 MB due to ISB data transfer limitations;
- display of a complete project area 1:250:000 coverage, including all spatial and attribute components, should be possible within 20 seconds on a standard configuration; and
- full database exports/imports to complete efficiently i.e. 30 minutes (reasonableness to be tested depending on final size of BEI database).

### **A.6.5. Volume/space Requirements**

#### ***A.6.5.1. Production Environment***

- Assumptions:
  - provincial coverage of 1:250,000 topographic basemaps with 9 layers (water, transportation, coast, contours etc.) ~ 1.5GB assuming minimum polygon scale of 1:250,000;
  - five years of historical data required on-line, due to rapid serial stages data change; and
  - additional historical information will be stored on CD-ROM (e.g. 20 years of Grizzly harvest data for time/series analysis).

- space requirements:
  - ~ 7.5 GB for five years on-line non-summarized data storage; and
  - ~ 5.0 GB for five years on-line summarized storage rolled up to the highest level that still meaningful.

#### **A.6.5.2. Test Environment**

- assumptions:
  - validation and testing database will reside on Environment's WLDUX1 server.
- space requirements:
  - ~2.5GB of available disk space is required for BEI project development.

### **A.6.6. Technical Strategy**

#### **A.6.6.1. Configuration:**

- a 486 66 MHz PC with 24 MB RAM proposed for minimum configuration (to be tested).

<b>DEVELOPMENT ENVIRONMENT</b>	<b>VERSION</b>
Oracle Designer/2000	V1.2
Oracle RDBMS	V7.3.2.2
Oracle Forms	V4.5.6.5.5F
Oracle Reports	V2.5 (3.0 planned)
Oracle Power Objects	V2
Oracle Web Server	V2.0
ArcInfo/AML	7.0.4
ArcView/Avenue	3.0
ArcPlot	7.0.4
ArcEdit	7.0.4
GOAT	V5
SQL*Plus	V3.1
PL/SQL	V7.3.2.2
SQL*Loader	V7.3.2.2
SQL*Net	V2.1.4.1.3c
Windows	3.1 (NT Planned)
HP/UX	10.10
UNIX print utility for all reporting	Current (upgrades planned)



**A.7. OTHER NON-TECHNICAL REQUIREMENTS**

- all scripts and source code must be developed to ISB standards and receive full QA by ISB since they will be supporting application in the long-term;
- all code must be delivered to ISB first, prior to installing or migrating into production;
- basemap update projects are conducted every few years (next planned for 1997). Interim changes are to be indicated on a temporary layer until the next baseline remapping project;
- Broad Ecosystem correlation and map generation are to be centralized functions;
- the database tables are to be generated from final maps for integrity purposes;
- GOAT will be used for plotting, formatting and providing standard symbol tables;
- initially queries are to be adhoc. Following three months of BEI Production standard queries, via an intuitive interface, are to be defined and implemented;
- the Ministry Master Data Registry will be used to enter BEI metadata; and
- a seamless master provincial coverage will be used for BEI map storage.

~~~

**A.8. SIGN OFF**

This document has been reviewed and accepted by the following project team members:

**Ministry of Environment, Lands & Parks:**

**Project Sponsor  
Bruce Pendergast**

\_\_\_\_\_  
*Signature* *Date*

**Business Champion  
Larry Lacelle**

\_\_\_\_\_  
*Signature* *Date*

**Application Manager  
Darren McKellar**

\_\_\_\_\_  
*Signature* *Date*

**Project Co-ordinator  
David Knox**

\_\_\_\_\_  
*Signature* *Date*

**Coopers & Lybrand Consulting**

**Partner  
Allan Hart**

\_\_\_\_\_  
*Signature* *Date*

**Project Manager  
Dave Rogers**

\_\_\_\_\_  
*Signature* *Date*

**Quality Assurance  
Dave Rogers**

\_\_\_\_\_  
*Signature* *Date*

**B. APPENDICES**

**B.1. FUNCTION DESCRIPTIONS**

**B.1.1. Manage Organism Taxa**

**BUSINESS FUNCTION HIERARCHY MODEL**



**Function ID:** MNTTAXA **Automated:** yes  
**Function Name:** Maintain ORGANISM TAXON

**Description:** Maintain the ORGANISM TAXON, the classification of organisms according to their presumed natural relationship, the TAXON SYNONYMS and TAXON REFERENCES.,

**Business Unit:** Wildlife System Administrator

**Initiating Events** A taxonomic authority has provided changes to the system administrator

**Outcomes**

**Information**

| Entity             | Create/Read/Update/Delete |
|--------------------|---------------------------|
| ORGANISM TAXON     | CRUD                      |
| STAKEHOLDER        | R                         |
| TAXON TYPE         | R                         |
| TAXON SYNONYM      | CRUD                      |
| STANDARD REFERENCE | R                         |
| TAXON REFERENCE    | CRUD                      |

For attribute details see Oracle Report: Entities and their Attributes

**Metrics** Data Volume: Initially about 10,000. Maximum approx. 100,000.  
 O initially and 10,000 maximum for synonyms  
 Growth about a 1% change per year

**Business Rules**

1. Every ORGANISM TAXON must be classified by one and only one TAXON TYPE.
2. Every ORGANISM TAXON belongs to a one and only one Kingdom.

**Special Validations:**

1. ORGANISM TAXON is structured as a hierarchy. The parent taxon must be validated in accordance with the hierarchy rules for the kingdom for example the parent ORGANISM TAXON must be from a higher level TAXON TYPE.
2. If entered taxon codes must be unique.
3. The introduced flag can only be entered if taxon type = species or subspecies
4. A taxon cannot be deleted if it has been used elsewhere in the system. It can be made obsolete with the entry of an end date however.
5. Valid Reasons for synonyms are "split", "consolidated", "renamed", "splintered"

**Special Processing:**

1. Must provide the ability to enter a synonym when the taxon is made "obsolete" because of splitting or consolidation or name changes.

2. Must be able to see full monomial, binomial, trinomial name, etc. (e.g. unit name1, unit name 2, unit name 3., whenever taxon is displayed. The binomial is appropriate for the species level, the trinomial to subspecies and the monomial for the rest.

**Manual Procedures**

1. If an ORGANISM TAXON is renamed split into two new taxon, splintered into a subset of the original and new taxon, or consolidated into another taxon. The rules for splitting, consolidating or altering taxonomic name including any changes required to synonyms at lower levels will be handled manually.
2. There is an impact on the taxon synonyms if a taxon of genus and below are made obsolete. Business rules need to be defined to the minimum number of levels for a wildlife observation needs to be defined. Business rules also need to be defined to identify what must happen to the synonyms of taxonomy classifications at a lower level when the synonyms of a higher level taxonomy change. Refer to RIC standards as they are developed

**Implementation**

1. Expect to use Oracles Forms.

**Notes:**

2. In the physical model all parts of a binomial or trinomial name may be included in the same record. The unit name1, 2, 3 is similar to a person's last name and first name, which are not kept in separate records.
3. Update date/timestamp and userid are need (this will be dealt with during design).
4. The original data will probably be loaded automatically from its source but changes will be manually entered. (Nov. 13/96 Working Group). SQL\*Loader will be used where needed.
5. Must ensure that all objects classified by taxon initially use taxon that are not obsolete

**Outstanding Questions**

1. Will there be an "alternate" taxon name?. Answer: Possibly
2. Do we need to keep a history of parentage? Answer: NO
5. .

**Function ID:** MNTADHOC **Automated:** yes  
**Function Name:** Maintain TAXON ADHOC GROUP

**Description:** Maintain a list of valid groupings other than taxon hierarchy, that may be used to classify organisms. Examples include “ungulate” in the animal kingdom or “woody shrub” in the plant kingdom., etc.

**Business Unit:** System Administrator

**Initiating Event:** None defined

**Outcomes** None defined

| Entity                   | Create/Read/Update/Delete |
|--------------------------|---------------------------|
| TAXON ADHOC GROUP        | CRUD                      |
| TAXON ADHOC GROUP MEMBER | CRUD                      |

For attribute details see Oracle Report: Entities and their Attributes

**Metrics** Data Volume: Initially 0, Maximum 500 . 10% growth per year for the TAXON ADHOC GROUP  
Initially 0, Maximum 100,000 for TAXON GROUP MEMBER.

**Business Rules** 1. Each TAXON ADHOC GROUP must have at least one TAXON ADHOC GROUP MEMBER.

**Special Validations:** 1. ORGANISM TAXON must be “active” (end date = null) when the TAXON ADHOC GROUP MEMBER is initially defined

**Special Processing:** None defined

**Manual Procedures:** 1. Only TAXON ADHOC GROUPS and TAXON ADHOC GROUP MEMBERSHIP authorized by the correlator will be added or deleted

**Implementation Notes:** 1. There is no requirement to retain “obsolete” TAXON ADHOC GROUP and TAXON ADHOC GROUP MEMBERS. They can simply be deleted.

**Resolved** 1. Should correlator be maintained in the corporate “stakeholder” entity?  
**ANSWER:** Yes, will be reflected in next ERD.

**Function ID:** MNTREF **Automated:** yes  
**Function Name:** Maintain STANDARD REFERENCES

**Description:** Maintain the STANDARD REFERENCE . The STANDARD REFERENCE is a published standard for a scientific entity such as taxon and includes the person, team, publication or organisation responsible for setting the standard.

**Business Unit:** System administrator

**Initiating Event:**

**Outcomes** Changes to STANDARD REFERENCES.

**Information**

| Entity             | Create/Read/Update/Delete |
|--------------------|---------------------------|
| STANDARD REFERENCE | CRUD                      |

For attribute details see Oracle Report: Entities and their Attributes

**Metrics** Function Frequency: 10% change per year  
Data Volume: Initially 4 Maximum 100 therefore 15 years capacity

**Business Rules** 1. None defined.

**Special Validations:** 1. None defined

**Special Processing:** 1. None defined.

**Manual Procedures** 1. Publication must be entered in a consistent format.

**Implementation Notes** 1. Expect to implement using Oracle Forms.

**Resolved:**

1. Check on format of publication. We may want to break it out into the standard bibliographic components. ANSWER: Standard Bibliographic fields for books and journals should be included, (GL).
2. Should Correlator be maintained in the corporate “stakeholder entity. **Answer:** yes and will be reflected in next ERD, (DC).

**Function ID:** MNTXNTYP **Automated:** yes  
**Function Name:** Maintain TAXON TYPEs

**Description:** Maintain a list of the TAXON TYPES such as Order, Family and Genus and the hierarchy rules between them

**Business Unit:** System Administrator

**Initiating Event:** Major new piece of scientific work.

**Outcomes** Redefinition of the taxonomic hierarchy.

|                    |               |                                  |
|--------------------|---------------|----------------------------------|
| <b>Information</b> | <b>Entity</b> | <b>Create/Read/Update/Delete</b> |
|                    | TAXON TYPE    | CRUD                             |

For attribute details see Oracle Report: Entities and their Attributes

**Metrics** Function Frequency: Updates only occur about once per decade.  
 Data Volume: For TAXON TYPE :Initially 24. Maximum 60.

**Business Rules** 1. none defined.

**Special Validations:** 1. Some Taxon Types are mandatory and others are optional. in the hierarchy (see table below)  
 2. The Parent TAXON TYPE must be from a higher level in the hierarchy  
 3. Parent and child TAXON TYPES must be from the same kingdom.

**Special Processing:** 1. Need to be able to view and report in hierarchical order.

**Manual Procedures** 1. Only taxonomic types recognized in the standard reference can be used. This will be handled manually.  
 2. The Parent TAXON TYPE must be no higher than the first mandatory TAXON TYPE which is at a higher level (lower sequence). Example: In the Animal Kingdom, a Species must have a parent of Genus, a Genus can have a parent of Tribe, sub-family or Family. A Family can have a parent of Suborder or Order. This will not be enforced by the system.

**Implementation Notes:** 1. Expect to use Oracle Forms.  
 2. No update or delete of records is allowed so that views and queries can be based on the values in the tables.  
 3. The Taxon hierarchy rules will be implemented as a simple sort sequence field in the entity to facilitate an end-user query.

| KINGDOM_ | SORT_SEQ | TAXON TYPE | MANDATORY |
|----------|----------|------------|-----------|
| ANIMALIA | 1        | PHYLUM     | Y         |
| ANIMALIA | 2        | SUBPHYLUM  | N         |
| ANIMALIA | 3        | CLASS      | Y         |

|          |    |            |   |
|----------|----|------------|---|
| ANIMALIA | 4  | SUBCLASS   | N |
| ANIMALIA | 5  | ORDER      | Y |
| ANIMALIA | 6  | SUBORDER   | N |
| ANIMALIA | 7  | FAMILY     | Y |
| ANIMALIA | 8  | SUBFAMILY  | N |
| ANIMALIA | 9  | TRIBE      | N |
| ANIMALIA | 10 | GENUS      | Y |
| ANIMALIA | 11 | SPECIES    | Y |
| ANIMALIA | 12 | SUBSPECIES | Y |
| PLANTAE  | 1  | PHYLUM     | Y |
| PLANTAE  | 2  | SUBPHYLUM  | N |
| PLANTAE  | 3  | CLASS      | Y |
| PLANTAE  | 4  | SUBCLASS   | N |
| PLANTAE  | 5  | ORDER      | Y |
| PLANTAE  | 6  | SUBORDER   | N |
| PLANTAE  | 7  | FAMILY     | Y |
| PLANTAE  | 8  | SUBFAMILY  | N |
| PLANTAE  | 9  | TRIBE      | N |
| PLANTAE  | 10 | GENUS      | Y |
| PLANTAE  | 11 | SPECIES    | Y |
| PLANTAE  | 12 | SUBSPECIES | Y |

|                          |                                       |                   |            |
|--------------------------|---------------------------------------|-------------------|------------|
| <b>Function ID:</b>      | <b>QRYTAXA</b>                        | <b>Automated:</b> | <b>yes</b> |
| <b>Function Name:</b>    | Taxon Report                          |                   |            |
| <b>Description:</b>      | Report taxon by kingdom or taxon type |                   |            |
| <b>Business Unit:</b>    | System Administrator                  |                   |            |
| <b>Initiating Event:</b> | When requested                        |                   |            |
| <b>Outcomes</b>          | Report                                |                   |            |

| Entity         | Create/Read/Update/Delete |
|----------------|---------------------------|
| ORGANISM TAXON | R                         |
| TAXON TYPE     | R                         |

For attribute details see Oracle Report: Entities and their Attributes

|                              |                                                                                                                                                                                                         |
|------------------------------|---------------------------------------------------------------------------------------------------------------------------------------------------------------------------------------------------------|
| <b>Selection Criteria</b>    | Kingdom, TAXON TYPE Name.<br>Examples: Generate a report for all animal families.                                                                                                                       |
| <b>Sort Sequence</b>         | Phylogenetic sort sequence + taxon name1 + taxon name2.<br>Types from Phylum to Family will be ordered by Phylogenetic Sort Sequence.<br>Types from Genus to Subspecies will be ordered alphabetically. |
| <b>Special Processing:</b>   | 1. None identified                                                                                                                                                                                      |
| <b>Implementation Notes:</b> | 1. Need to be able to sort and view the full binomial and trinomial name.                                                                                                                               |
| <b>Outstanding Questions</b> | 1. none identified                                                                                                                                                                                      |

SAMPLE:

| Taxon Type | Taxon Name                          | English Name | Taxon Code |
|------------|-------------------------------------|--------------|------------|
| KINGDOM    | ANIMALIA                            |              |            |
| ORDER      | CETACEA                             | Whales       |            |
| FAMILY:    | BALAENIDAE:                         | Right Whales |            |
| SPECIES    | Balaena glacialis Muller            | Right Whale  | M-BAGL     |
| FAMILY     | BALAENOPTERIDAY:                    | Rorquals     |            |
| SPECIES    | Balaenoptera acutorostrata Lacepede | Minke Whale  | M-BAAC     |
| SPECIES    | Balaenoptera musculus (Linnaeus)    | Blue Whale   | M-BAMU     |

**Function ID:** QRYADGRP **Automated:** yes  
**Function Name:** Report Adhoc Groups

**Description:** Report on taxa by a classification group other than taxa.

**Business Unit:** System Administrator

**Initiating Event:** When requested

**Outcomes** Report

**Information**

| Entity             | Create/Read/Update/Delete |
|--------------------|---------------------------|
| ORGANISM TAXON     | R                         |
| TAXON TYPE         | R                         |
| ADHOC GROUP        | R                         |
| ADHOC GROUP MEMBER | R                         |

For attribute details see Oracle Report: Entities and their Attributes

**Metrics** Function Frequency: .

**Selection Criteria** Adhoc Group ID, Kingdom, Taxon type. Taxon

**Sort Sequence** Taxon type. Phylogenetic sort sequence + taxon name1 + taxon name2 + taxon name 3 (see implementation notes 1).

**Special Processing:** None identified

**Manual Procedures:** None identified

**Implementation Notes:** 1. Need to be able to sort and view the full binomial and trinomial name .

**Outstanding Questions:** 1. none

EXAMPLE:

Adhoc Group: MOF 12 - Dwarf Woody Plants

| Code     | Family    | Species                      | English Name |
|----------|-----------|------------------------------|--------------|
| ANDRPOL  | ERICACEAE | Andromeda polifolia          | bog-rosemary |
| ARCTALP1 |           | Arctostaphylos alpine alpina | bearberry    |

**B.1.2. Maintain Ecological Classes (MNGECOREF)**

**Business Function Hierarchy**

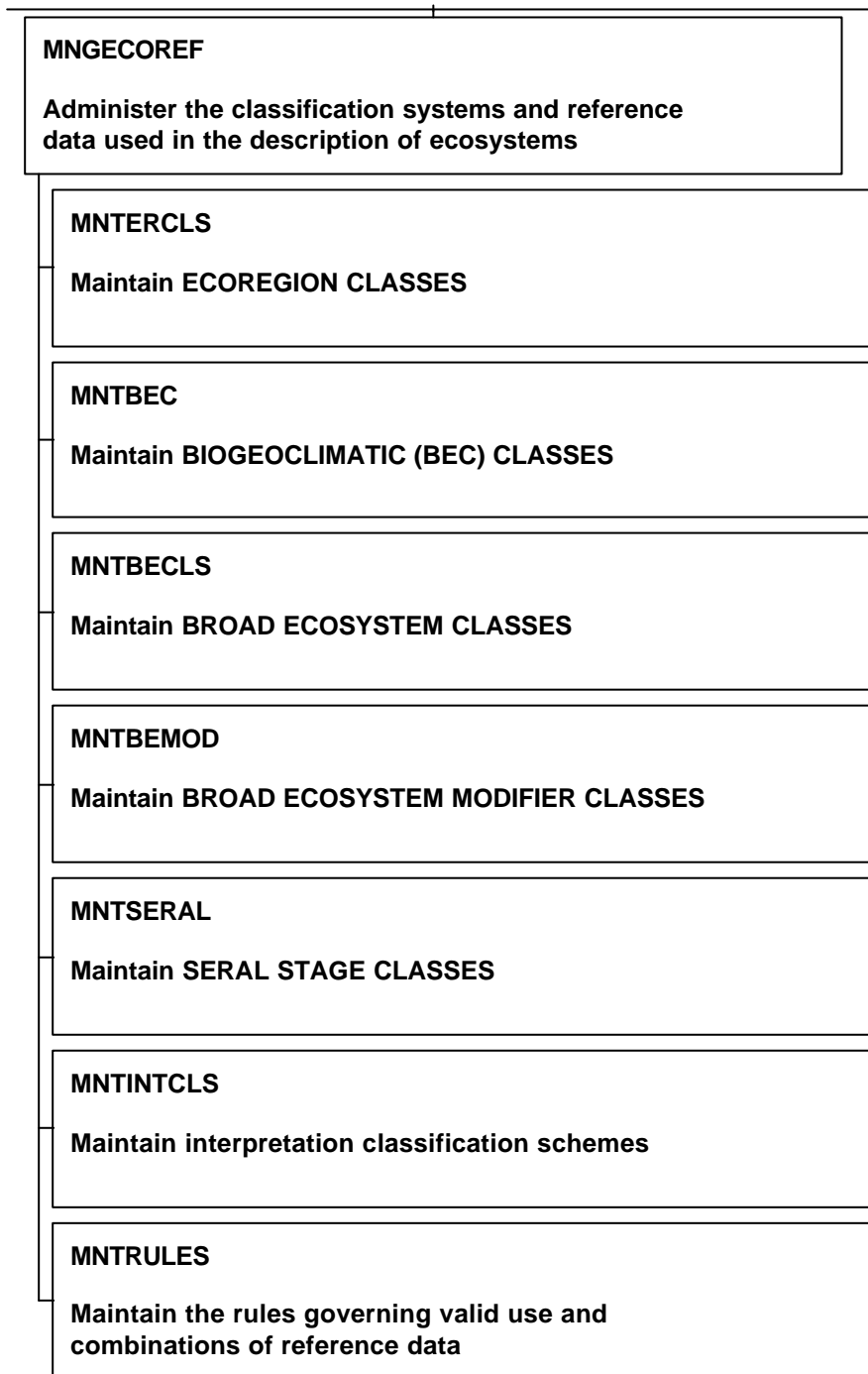

**Function ID:** MINTERCLS **Automated:** yes  
**Function Name:** Maintain ECOREGION CLASS

**Description:** Maintain a list of ECOREGION CLASSES . The Ecoregion classification system stratifies British Columbia's terrestrial and marine ecosystem complexity into discrete geographical units at five levels: Ecodomains and Ecodivisions, Ecoprovinces, Ecoregions and Ecosections .

**Business Unit:** Correlator

**Initiating Event:** Changes to Biogeoclimatic classification.

**Outcomes** Updates may trigger changes in dependent data.

| Entity                    | Create/Read/Update/Delete |
|---------------------------|---------------------------|
| ECOREGION HIERARCHY LEVEL | CRUD                      |
| ECOREGION CLASS           | CRUD                      |

For entity attribute details see Oracle Report: Entities and their Attributes

**Metrics**  
 Function Frequency: Changes whenever BEC changes. (i.e. annually)  
 Data Volume: 3 Ecodomains, 8 Ecodivisions, 10 Ecoprovinces, 47 Ecoregions, 116 Ecosections

**Business Rules**

1. Every point in the province is covered by one and only one Ecosection.
2. For each Ecosection there is one and only one Ecoregion.
3. For each Ecoregion there is one and only Ecoprovince.
4. For each Ecoprovince there is one and only Ecodivision.
5. For each Ecodivision there is one and only one Ecodomain.
6. Each ECOREGION CLASS may classify one or more ECOREGION UNITS.

**Special Validations:**

1. Level can be Ecodomain, Ecodivision, Ecoprovince, Ecoregion or Ecosection.
2. Each Ecodomain must be defined down to the Ecosection level.

**Special Processing:**

1. Need to retain history of old codes (handled by start and end dates)
2. For a new Ecoregion class default Start Date to Current System Date

**Manual Procedures:** None defined

**Implementation Notes:**

1. Changing in Ecoregion can cause a significant amount of remapping.
- 2.

**Function ID:** MNTBEC **Automated:** yes  
**Function Name:** Maintain BIOGEOCLIMATIC CLASSES (BEC).

**Description:** Maintain the BIOGEOCLIMATIC CLASSES. The classification is a hierarchical system that integrates climate, vegetation and site classifications at a broad landscape level. The zonal or regional climate (reflected by vegetation and soil relationships) defines the basic biogeoclimatic unit, the subzone. These units are grouped into zones and may be further subdivided into variants based on further refinements of climate (e.g. wetter, drier, snowier) and also phases.

**Business Unit:** Cartographic Unit: GIS Technician.

**Initiating Event Outcomes** Updates are received from Ministry of Forests.  
 BEC Classes updated

| Information | Entity               | Create/Read/Update/Delete |
|-------------|----------------------|---------------------------|
|             | BEC HIERARCHY LEVEL  | CRUD                      |
|             | BIOGEOCLIMATIC CLASS | CRUD                      |

For entity attribute details see Oracle Report: Entities and their Attributes

**Metrics** Function Frequency:  
 Data Volume: 14 BEC zones, 90 zone/subzones,  
 160 zone/subzone/variants, 300 zone/subzone/  
 variants/phase

**Business Rules** 1. Each BIOGEOCLIMATIC CLASS.zone must have at least one BIOGEOCLIMATIC CLASS.subzone The only exception is the Alpine tundra zone. For the system however the Alpine tundra zone “un” will be used

**Special Validations:** 1. 1. The classification is completely hierarchical (i.e., a phase must be contained in a variant, subzone and a zone. ) The order is zone, subzone, variant, phase  
 The combination of zone, subzone, variant and phase is unique.

**Special Processing:** 1. When entering a new BEC default the Start Date to the current system date

**Manual Procedures** 1. When a BEC changes, reclassification and remapping may be required. This represents considerable effort. For this reason a moratorium on BEC changes may be imposed over the next 5 years.

**Implementation Notes** 1. The full BEC code (the concatenation of the BEC code and its parent BEC Code) needs to be derived  
 2. Valid combinations of BEC and Broad Ecosystem Class are retained by the MNTRULES function.  
 3. Valid combinations of BEC and ECOREGION Classes will be maintained spatially.

**Outstanding Questions**

1. What changes when a new version of BEC is issued? **Assumption:** The mapping of the BEC units. A version number will be placed on the BEC Units. The Old classifications may also no longer be valid, and new ones may be added but this will be handled with start and end dates on the classification.

**Function ID:** MNTBECLS **Automated:** yes  
**Function Name:** Maintain BROAD ECOSYSTEM CLASSES

**Description:** Maintain the list of BROAD ECOSYSTEM CLASSES used to describe a geographic area in terms of the distinct dominant vegetative cover, non-vegetative cover (such as lakes or rock outcrops) it supports.

**Business Unit:** Correlator

**Initiating Event:** When Ministry of Forests changes their site series.

**Outcomes** None

|                    |                       |                                  |
|--------------------|-----------------------|----------------------------------|
| <b>Information</b> | <b>Entity</b>         | <b>Create/Read/Update/Delete</b> |
|                    | BROAD ECOSYSTEM CLASS | CRUD                             |

For entity attribute details see Oracle Report: Entities and their Attributes

**Metrics** Function Frequency: About once every 5 years  
 Data Volume: Initially 120 Maximum: 250

**Business Rules** There is fairly rigid association between Broad Ecosystem Classes to a group of BEC Units.

**Special Validations:** 1. A BROAD ECOSYSTEM CLASS cannot be deleted if it is referenced by another part of the system.

**Special Processing:** 1. When entering a new BROAD ECOSYSTEM CLASS, default Start date to Current System Date.

**Manual Procedures** 1. The following need to be adjusted if a new BROAD ECOSYSTEM CLASS is added or one is ended:

- BROAD ECOSYSTEM CLASS MODIFIER RULE
- BROAD ECOSYSTEM CLASS SERAL STAGE RULE
- BROAD ECOSYSTEM CLASS BEC RULE
- PROVINCIAL BEI SUITABILITY

**Implementation Notes** 1. None identified.

| <b>Function ID:</b>            | <b>MNTBEMOD</b>                                                                                                                                                                                                                                                                    | <b>Automated:</b>                  | yes         |        |                           |                                |      |
|--------------------------------|------------------------------------------------------------------------------------------------------------------------------------------------------------------------------------------------------------------------------------------------------------------------------------|------------------------------------|-------------|--------|---------------------------|--------------------------------|------|
| <b>Function Name:</b>          | <b>Maintain BROAD ECOSYSTEM CLASS MODIFIERS</b>                                                                                                                                                                                                                                    |                                    |             |        |                           |                                |      |
| <b>Description:</b>            | Maintain the list of BROAD ECOSYSTEM CLASS MODIFIERS. The modifiers are used to refine the classification of a broad ecosystem based on site specific characteristics.                                                                                                             |                                    |             |        |                           |                                |      |
| <b>Business Unit:</b>          | Correlator                                                                                                                                                                                                                                                                         |                                    |             |        |                           |                                |      |
| <b>Initiating Event:</b>       | None                                                                                                                                                                                                                                                                               |                                    |             |        |                           |                                |      |
| <b>Outcomes</b>                | None                                                                                                                                                                                                                                                                               |                                    |             |        |                           |                                |      |
| <b>Information</b>             | <table border="1"> <thead> <tr> <th>Entity</th> <th>Create/Read/Update/Delete</th> </tr> </thead> <tbody> <tr> <td>BROAD ECOSYSTEM CLASS MODIFIER</td> <td>CRUD</td> </tr> </tbody> </table>                                                                                       |                                    |             | Entity | Create/Read/Update/Delete | BROAD ECOSYSTEM CLASS MODIFIER | CRUD |
| Entity                         | Create/Read/Update/Delete                                                                                                                                                                                                                                                          |                                    |             |        |                           |                                |      |
| BROAD ECOSYSTEM CLASS MODIFIER | CRUD                                                                                                                                                                                                                                                                               |                                    |             |        |                           |                                |      |
|                                | For entity attribute details see Oracle Report: Entities and their Attributes                                                                                                                                                                                                      |                                    |             |        |                           |                                |      |
| <b>Metrics</b>                 | Function Frequency:                                                                                                                                                                                                                                                                | Very stable. Once every 5-10 years |             |        |                           |                                |      |
|                                | Data Volume:                                                                                                                                                                                                                                                                       | Initially: 9                       | Maximum: 36 |        |                           |                                |      |
| <b>Business Rules</b>          | None                                                                                                                                                                                                                                                                               |                                    |             |        |                           |                                |      |
| <b>Special Validations:</b>    | None                                                                                                                                                                                                                                                                               |                                    |             |        |                           |                                |      |
| <b>Special Processing:</b>     | When creating a new code, default start date to current system date.                                                                                                                                                                                                               |                                    |             |        |                           |                                |      |
| <b>Manual Procedures</b>       | <ol style="list-style-type: none"> <li>The following may need to be changed if a new BROAD ECOSYSTEM CLASS MODIFIER is added or one is ended <ul style="list-style-type: none"> <li>BROAD ECOSYSTEM CLASS MODIFIER RULE</li> <li>PROVINCIAL BEI SUITABILITY</li> </ul> </li> </ol> |                                    |             |        |                           |                                |      |
| <b>Implementation Notes</b>    | <ol style="list-style-type: none"> <li>The valid combinations of BROAD ECOSYSTEM CLASS and BROAD ECOSYSTEM CLASS MODIFIER is maintained by the function MNTRULES</li> </ol>                                                                                                        |                                    |             |        |                           |                                |      |
| <b>Resolved Questions:</b>     | Could a BROAD ECOSYSTEM CLASS MODIFIER ever become “obsolete”?<br><b>Assumption:</b> Yes                                                                                                                                                                                           |                                    |             |        |                           |                                |      |

| <b>Function ID:</b>           | <b>ECOSERSTG</b>                                                                                                                                                                                                                         | <b>Automated:</b>               | yes |        |                           |                   |      |
|-------------------------------|------------------------------------------------------------------------------------------------------------------------------------------------------------------------------------------------------------------------------------------|---------------------------------|-----|--------|---------------------------|-------------------|------|
| <b>Function Name:</b>         | <b>Maintain SERAL STAGE CLASSES</b>                                                                                                                                                                                                      |                                 |     |        |                           |                   |      |
| <b>Description:</b>           | Maintain the list of SERAL STAGE CLASSES. A seral stage is a named stage in the general transition from a non-vegetated pioneer state to an old forested state.                                                                          |                                 |     |        |                           |                   |      |
| <b>Business Unit:</b>         | Correlator                                                                                                                                                                                                                               |                                 |     |        |                           |                   |      |
| <b>Initiating Event:</b>      | Ministry of Forests changes a seral stage.                                                                                                                                                                                               |                                 |     |        |                           |                   |      |
| <b>Outcomes</b>               | None                                                                                                                                                                                                                                     |                                 |     |        |                           |                   |      |
| <b>Information</b>            | <table border="1"> <thead> <tr> <th>Entity</th> <th>Create/Read/Update/Delete</th> </tr> </thead> <tbody> <tr> <td>SERAL STAGE CLASS</td> <td>CRUD</td> </tr> </tbody> </table>                                                          |                                 |     | Entity | Create/Read/Update/Delete | SERAL STAGE CLASS | CRUD |
| Entity                        | Create/Read/Update/Delete                                                                                                                                                                                                                |                                 |     |        |                           |                   |      |
| SERAL STAGE CLASS             | CRUD                                                                                                                                                                                                                                     |                                 |     |        |                           |                   |      |
|                               | For entity attribute details see Oracle Report: Entities and their Attributes                                                                                                                                                            |                                 |     |        |                           |                   |      |
| <b>Metrics</b>                | Function Frequency:                                                                                                                                                                                                                      | Very stable unlikely to change. |     |        |                           |                   |      |
|                               | Data Volume:                                                                                                                                                                                                                             | 7                               |     |        |                           |                   |      |
| <b>Business Rules</b>         | None                                                                                                                                                                                                                                     |                                 |     |        |                           |                   |      |
| <b>Special Validations:</b>   | None                                                                                                                                                                                                                                     |                                 |     |        |                           |                   |      |
| <b>Special Processing:</b>    | 1. .                                                                                                                                                                                                                                     |                                 |     |        |                           |                   |      |
| <b>Manual Procedures</b>      | <ol style="list-style-type: none"> <li>The following may need to be changed if a SERAL STAGE CLASS is added <ul style="list-style-type: none"> <li>BROAD ECOSYSTEM CLASS SERAL STAGE RULES</li> </ul> </li> </ol>                        |                                 |     |        |                           |                   |      |
| <b>Implementation Notes:</b>  | <ol style="list-style-type: none"> <li>Should not be able to delete any seral stage that is or has been used.</li> <li>Valid combinations of BROAD ECOSYSTEM CLASS and SERAL STAGE CLASS are handled by the function MNTRULES</li> </ol> |                                 |     |        |                           |                   |      |
| <b>Outstanding Questions:</b> | <ol style="list-style-type: none"> <li>Should VRI from MOF be maintained?. Should age classes instead of seral stages be used? <b>Answer:</b> This could be done from MoF generalized 1:250,000, but needs to be discussed.</li> </ol>   |                                 |     |        |                           |                   |      |

| <b>Function ID:</b>          | <b>MNTINTCLS</b>                                                                                                                                                                   | <b>Automated:</b>  | yes                     |        |                           |                      |      |
|------------------------------|------------------------------------------------------------------------------------------------------------------------------------------------------------------------------------|--------------------|-------------------------|--------|---------------------------|----------------------|------|
| <b>Function Name:</b>        | <b>Maintain INTERPRETATION CLASSES</b>                                                                                                                                             |                    |                         |        |                           |                      |      |
| <b>Description:</b>          | Maintain a list of INTERPRETATION CLASS by interpretation class scheme. These are used to rank ecosystems for wildlife.                                                            |                    |                         |        |                           |                      |      |
| <b>Business Unit:</b>        | Correlator                                                                                                                                                                         |                    |                         |        |                           |                      |      |
| <b>Initiating Event:</b>     | None                                                                                                                                                                               |                    |                         |        |                           |                      |      |
| <b>Outcomes</b>              | None                                                                                                                                                                               |                    |                         |        |                           |                      |      |
| <b>Information</b>           | <table border="1"> <thead> <tr> <th>Entity</th> <th>Create/Read/Update/Delete</th> </tr> </thead> <tbody> <tr> <td>INTERPRETATION CLASS</td> <td>CRUD</td> </tr> </tbody> </table> |                    |                         | Entity | Create/Read/Update/Delete | INTERPRETATION CLASS | CRUD |
| Entity                       | Create/Read/Update/Delete                                                                                                                                                          |                    |                         |        |                           |                      |      |
| INTERPRETATION CLASS         | CRUD                                                                                                                                                                               |                    |                         |        |                           |                      |      |
|                              | For entity attribute details see Oracle Report: Entities and their Attributes                                                                                                      |                    |                         |        |                           |                      |      |
| <b>Metrics</b>               | Function Frequency:                                                                                                                                                                | Seldom updated     |                         |        |                           |                      |      |
|                              | Data Volume:                                                                                                                                                                       | Initially Under 40 | Max: 200 over 15 years. |        |                           |                      |      |
| <b>Business Rules</b>        | None                                                                                                                                                                               |                    |                         |        |                           |                      |      |
| <b>Special Validations:</b>  | None                                                                                                                                                                               |                    |                         |        |                           |                      |      |
| <b>Special Processing:</b>   | None                                                                                                                                                                               |                    |                         |        |                           |                      |      |
| <b>Manual Procedures</b>     | None identified                                                                                                                                                                    |                    |                         |        |                           |                      |      |
| <b>Implementation Notes:</b> | 1. Interpretation Class Scheme No will be implemented as a domain.                                                                                                                 |                    |                         |        |                           |                      |      |
| <b>Resolved:</b>             | 1. Will the interpretation classification system be different for DEI? <b>Answer:</b> no.                                                                                          |                    |                         |        |                           |                      |      |

|                          |                                                                                        |                   |     |
|--------------------------|----------------------------------------------------------------------------------------|-------------------|-----|
| <b>Function ID:</b>      | <b>MNTRULES</b>                                                                        | <b>Automated:</b> | yes |
| <b>Function Name:</b>    | <b>Maintain Class Rules</b>                                                            |                   |     |
| <b>Description:</b>      | Maintain the rules governing valid use and combinations of class codes.                |                   |     |
| <b>Business Unit:</b>    | Correlator                                                                             |                   |     |
| <b>Initiating Event:</b> | Change in seral stage, broad ecosystem class, broad ecosystem class modifiers, or BEC. |                   |     |
| <b>Outcomes</b>          | None                                                                                   |                   |     |

| Information | Entity                                    | Create/Read/Update/Delete |
|-------------|-------------------------------------------|---------------------------|
|             | BROAD ECOSYSTEM CLASS                     | R                         |
|             | BIOGEOCLIMATIC CLASS                      | R                         |
|             | BROAD ECOSYSTEM BEC CLASS RULE            | CRUD                      |
|             | BROAD ECOSYSTEM CLASS MODIFIER<br>RULE    | CRUD                      |
|             | BROAD ECOSYSTEM CLASS BEC RULE            | CRUD                      |
|             | SERAL STAGE CLASS                         | R                         |
|             | ECOSECTION BEC CLASS RULE                 | CRUD                      |
|             | BROAD ECOSYSTEM CLASS SERAL<br>STAGE RULE | CRUD                      |

For entity attribute details see Oracle Report: Entities and their Attributes

|                              |                                                                                                           |                                                                       |
|------------------------------|-----------------------------------------------------------------------------------------------------------|-----------------------------------------------------------------------|
| <b>Metrics</b>               | Function Frequency:<br>Data Volume:                                                                       | BROAD ECOSYSTEM CLASS SERAL STAGE<br>RULE: initially 720 maximum 1500 |
| <b>Business Rules</b>        | None                                                                                                      |                                                                       |
| <b>Special Validations:</b>  | None                                                                                                      |                                                                       |
| <b>Special Processing:</b>   | None identified                                                                                           |                                                                       |
| <b>Manual Procedures</b>     | None identified                                                                                           |                                                                       |
| <b>Implementation Notes:</b> | 1. May be implemented as one "rules" entity,                                                              |                                                                       |
| <b>Resolved Questions:</b>   | 1. Are there valid combinations of BROAD ECOSYSTEM CLASS and 2 or more CLASS MODIFIERS? <b>Answer:</b> NO |                                                                       |

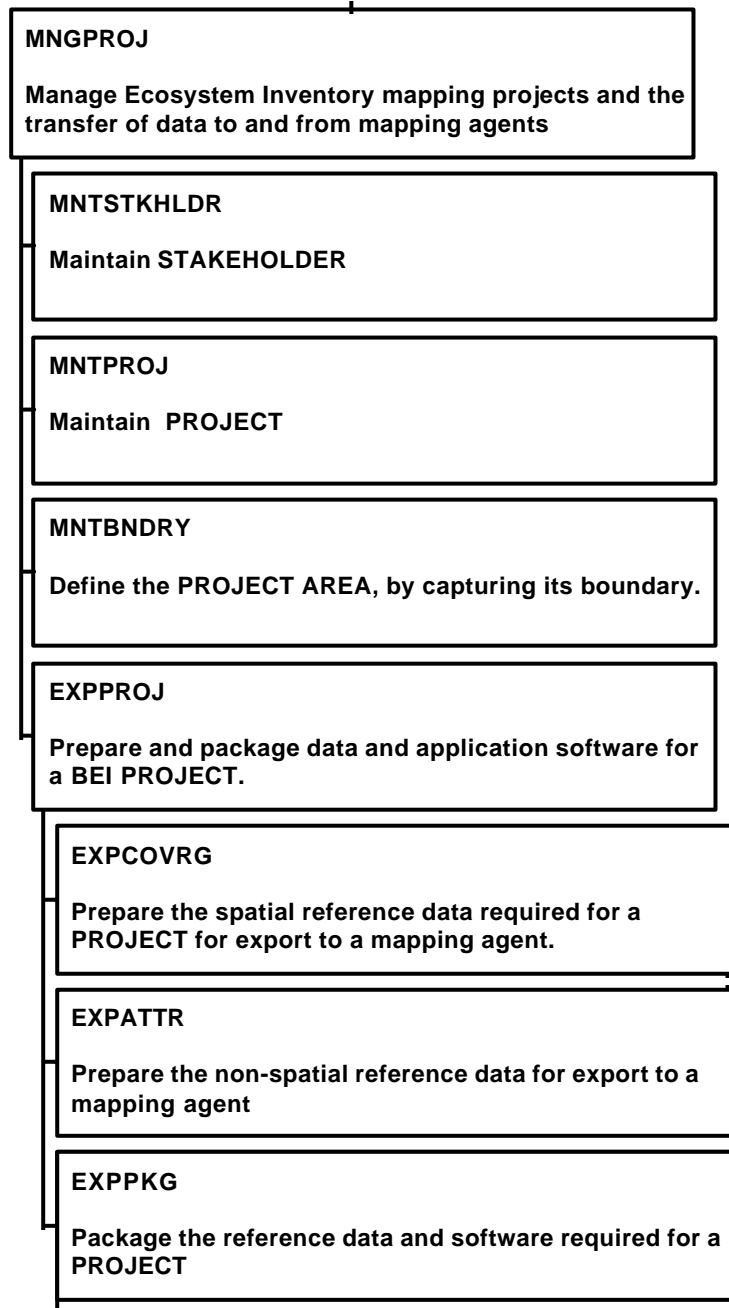
**B.1.3. Maintain Projects (MNGPROJ)****Business Function Hierarchy**

**Function ID:** MNTPROJ **Automated:** yes  
**Function Name:** Maintain Project

**Description:** Maintain the information necessary to identify a project and its scope.

**Business Unit:** Habitat Section: Mapping Unit

**Initiating Event:** When a project is approved to proceed.

**Outcomes** Project defined

**Information**

| Entity              | Create/Read/Update/Delete |
|---------------------|---------------------------|
| STAKEHOLDER         | R                         |
| PROJECT             | CRUD                      |
| PROJECT TAXON       | CRUD                      |
| PROJECT FEATURE     | CRUD                      |
| PROJECT STAKEHOLDER | CRUD                      |

For entity attribute details see Oracle Report: Entities and their Attributes

**Metrics** Frequency: 3 BEI per year  
less than 50 taxon per project and usually no more than 10  
usually no more than 2 interpretation types per project  
Volume:

**Business Rules**

1. A PROJECT may target one or more PROJECT TAXON
2. A PROJECT may be conducting one or more PROJECT INTERPRETATIONS
3. A PROJECT may be defining one or more PROJECT FEATURES.

**Special Validations:**

1. Valid project types include: BEI, DEI ESSERII, SPECIES INV
2. If end date is entered, then start date is also necessary.
3. End date must be greater than or equal to start date.
4. Start date may be equal to or less than the current date.
5. ORGANISM TAXON must be active for the period the project is active.
6. ORGANISM TAXON may be at the species or sub-species level.

**Special Processing:** 1. none identified

**Manual Procedures**

1. Projects adjacent to each other will be directly co-ordinated through the contracts.
2. Mappers map to the project boundaries only.

**Implementation Notes:**

1. The relationship of a project to mapsheet will be NOT be handled here. It will be handled through a spatial overlay.

**Outstanding  
Questions:**

1. Is there a business need to retain a reference to more than one stakeholder of a project (e.g. the mapping contractor and the internal project manager?): Answer: Yes

**Function ID:** MNTBNDRY **Automated:** yes  
**Function Name:** Capture Project Boundary  
**Description:** Define the boundary of the geographic area covered by the project.  
**Business Unit:** Habitat Section: Cartographic Unit  
**Initiating Event:** When the project is approved and defined.  
**Outcomes** None

**Information**

| Entity                                                                                                                                                                                                                                                                | Create/Read/Update/Delete |
|-----------------------------------------------------------------------------------------------------------------------------------------------------------------------------------------------------------------------------------------------------------------------|---------------------------|
| The SPATIAL REPRESENTATION (e.g. polygon) of a feature at a particular scale is represented by the entity FEATURE SPATIAL REPRESENTATION. One or more of the following types of feature coverages are used to determine the boundary. This is not an exhaustive list. |                           |
| 1) NTS Waterbodies                                                                                                                                                                                                                                                    | R                         |
| 2) BIOGEOCLIMATIC UNIT                                                                                                                                                                                                                                                | R                         |
| 3) ECOREGION UNIT                                                                                                                                                                                                                                                     | R                         |
| 4) ECOSYSTEM MAP UNIT                                                                                                                                                                                                                                                 | R                         |
| 5) NTS Mapsheet                                                                                                                                                                                                                                                       | R                         |
| 6) Provincial and International Boundaries                                                                                                                                                                                                                            | R                         |
| PROJECT FEATURE                                                                                                                                                                                                                                                       | CRUD                      |
| PROJECT AREA                                                                                                                                                                                                                                                          | CRUD                      |
| FEATURE GEOMETRIC REPRESENTATION                                                                                                                                                                                                                                      | CRUD                      |

For entity attribute details see Oracle Report: Entities and their Attributes

**Metrics** Function Frequency: 3 BEI mapping projects per year.  
 Data Volume: One per project.

**Business Rules** 1. Only approved base maps can be used.  
 2. Boundaries must be digitized to standards defined by the Branch.

**Special Validations:** Project boundaries should not be overlapping

**Special Processing:** 1. An automated process to:

- Set up baseline coverages in ArcEdit, set tolerances for snapping, and set edit features;
- Provide the ability to choose existing features;

Provide the ability to digitize a line and Start the “ADD” process;

- Take selected boundary arcs and save to a new coverage.
- Clean and build to close polygons and remove dangles within tolerances.
- Assign polygon number to polygon.
- Visual verification of the boundary by displaying the boundary and basemap.
- Create a new record in PROJECT FEATURE for PROJECT AREA.

**Manual Procedures:** 1.

**Implementation  
Notes:**

1. This process will be handled within the GIS
2. ARC EDIT and a AML will be used to automate this process.
3. The source of the boundary will be digital, using existing features b) heads up digitizing
4. A buffer area around the project will be provided. The size of the buffer is variable. It will depend on the largest Ecosection being mapped. (Revisit during design to see if this increases cost).

**Resolved  
Questions:**

1. Will the buffer area around the project be handled as a second polygon?  
**Answer:** Yes
2. Could the boundary be changed during the life of the project? **Answer:** Yes

**Function ID:** EXPCOVRG **Automated:** yes  
**Function Name:** Prepare Project Reference Coverages

**Description:** Prepare the reference coverages such as the BEC, NTS Water bodies, Ecosystems, any neighbouring BEI coverages and Project boundary for export to the Mapping Contractor. This includes the preparation (via overlay) of the ECOSECTION BEC CLASS RULES that are valid for the project data capture.

**Business Unit:** Habitat Section Cartographic Unit

**Initiating Event:** Project approval

**Outcomes** Baseline Coverages ready for the mapping contractor.

| Information | Entity                                                                                            | Create/Read/Update/Delete |
|-------------|---------------------------------------------------------------------------------------------------|---------------------------|
|             | FEATURE SPATIAL REPRESENTATION (the actual polygons at a particular scale) of the following types |                           |
|             | 1) NTS Waterbodies                                                                                | R                         |
|             | 2) BIOGEOCLIMATIC UNIT                                                                            | R                         |
|             | 3) ECOREGION UNIT                                                                                 | R                         |
|             | 4) ECOSYSTEM MAP UNIT                                                                             | R                         |
|             | 5) NTS Mapsheet                                                                                   | R                         |
|             | 6) Provincial and International Boundaries                                                        | R                         |
|             | PROJECT AREA                                                                                      | R                         |
|             | FEATURE GEOMETRIC REPRESENTATION                                                                  | CRUD                      |
|             | ECOSECTION CLASS BEC RULES                                                                        | CRUD                      |
|             | PROJECT FEATURE                                                                                   | CRUD                      |

For entity attribute details see Oracle Report: Entities and their Attributes

**Metrics** Frequency: Once per project  
Volume:

**Business Rules** 1. All baseline coverages will be clipped using the buffered project boundary coverage

**Special Validations:** 1. None identified

**Special Processing:** This process is based on the assumption that the clipping of basemap data to project area will be an automated process conducted by the Ministry to prepare the baseline coverages. Coverages will not be combined into a single coverage.

Automate the following:

- I. Prepare Ecosystem polygon cover by:
  - A. Dropping all region layers from Ecoregions region coverage to isolate Ecosystem polygons;
  - B. Adding a record in PROJECT FEATURE to identify the Ecosystems

- in the scope of the project. Entries in the PROJECT FEATURE will be used to subset the non-spatial data downloaded to the contractor.
- C. Converting to the export format prescribed by the Ministry.
  - II. Repeat the process for each coverage being used

- Manual Procedures**
- 1. Mapping contractors cannot modify the boundaries of the polygons
  - 2. Existing BEI mapping can only be changed in conjunction with the provincial correlator.
  - 3. There is a moratorium on BEC and Ecosection changes. At the point when it is lifted, the Ministry will manually ensure there are no contracts out.
  - 4. The copy placed on the FTP site will be purged immediately. The copy placed in the temporary work area will be purged after the baseline mapping has been approved. This will be done using standard tools available to the Ministry.

- Implementation notes:**
- 1. Each Coverage will be converted to an ArcExport file using the export function.
  - 2. Expect to automate the exports using an AML.

- Resolved Questions:**
- 1. Can the BEC and ECOSECTION coverages be overlaid to give valid combinations? ANSWER: YES. If so these could possible be stored in the PROJECT FEATURE and used for non-spatial data entry validation. **Answer:** Combinations will be added to the ECOSECTION BEC CLASS RULES.

**Function ID:** EXPATTR **Automated:** yes  
**Function Name:** Prepare Initial Project Non-spatial data.

**Description:** Select and convert the non-spatial attribute data the mapping contractor/s require to capture and validate the area being mapped. The data is captured for export in a format prescribed by the BEI technical standards document.

**Business Unit:** Cartographic Unit

**Initiating Event:** Project approved

**Outcomes** Non-spatial data prepared for the mapping contractor.

**Information**

| Entity                         | Create/Read/Update/Delete |
|--------------------------------|---------------------------|
| PROJECT FEATURE                |                           |
| BROAD ECOSYSTEM MAP UNIT       | R                         |
| BROAD ECOSYSTEM COMPONENT      | R                         |
| BROAD ECOSYSTEM SERAL STAGE    | R                         |
| BIOGEOCLIMATIC CLASS           | R                         |
| BROAD ECOSYSTEM CLASS          | R                         |
| BROAD ECOSYSTEM CLASS MODIFIER | R                         |
| BROAD ECOSYSTEM CLASS MODIFIER | R                         |
| RULE                           |                           |
| BROAD ECOSYSTEM CLASS BEC RULE | R                         |
| SERAL STAGE CLASS              | R                         |
| BROAD ECOSYSTEM CLASS SERAL    | R                         |
| STAGE RULE                     |                           |
| ECOSECTION CLASS BEC RULES     | R                         |
| 4 to 5 export files            | CRUD                      |

For entity attribute details see Oracle Report: Entities and their Attributes

**Metrics** Frequency: 1 time per project.  
Volume:

**Business Rules** None identified

**Special Validations:** None identified

**Special Processing:**

1. Select the data required by the project based on the information in PROJECT FEATURE.
2. Convert the data into the export format prescribed by the technical standards.

**Manual Procedures:** 1. none identified.

**Implementation Notes:**

1. A spatial overlay of the buffered project boundary and baseline reference coverages will identify the Ecosections, BEC classes, and broad ecosystem units etc. required by the project and will be exported as a table. This

information is stored in PROJECT FEATURE

- Resolved Questions:** 1. Should the detail in PROJECT FEATURE be deleted? If so when? **Answer:** No, Mapping metadata needs to be associated with the project (DC).

**Function ID:** EXPPKG **Automated:** yes  
**Function Name:** Package Initial Project Data

**Description:** Package the reference data and software required for the project into a form that is easily downloaded by the mapping contractor.

**Business Unit:** None

**Initiating Event:** None

**Outcomes** None

**Information**

| Entity                            | Create/Read/Update/Delete |
|-----------------------------------|---------------------------|
| Oracle Export File(s)             | R                         |
| ArcExport File(s)                 | R                         |
| DDC application                   | R                         |
| Project Zip or Executable File(s) | C                         |

For entity attribute details see Oracle Report: Entities and their Attributes

**Metrics** Frequency: 1 time per project.  
Volume:

**Business Rules** None

**Special Validations:** None

**Special Processing:**

1. Create a dedicated directory for the project on the FTP site.
2. Compress the information needed by the contractor for the project into a zip file or self extracting executable.

**Manual Procedures:** A section in the standards is required to detail how to obtain the project data.

**Implementation Notes:**

1. One userid for all mapping contractors to use.
2. On FTP site a devoted directory by project number.
3. Common items required by all projects such as the Ministry logo will be retained in a directory for contractors to download.
4. Install Shield is the Ministry's planned standard for contractor installation. Packaging must be consistent with this requirement.

**Outstanding Questions:**

1. none identified

**B.1.4. Manage BEI**

**B.1.4.1. Manage BEI Baseline**

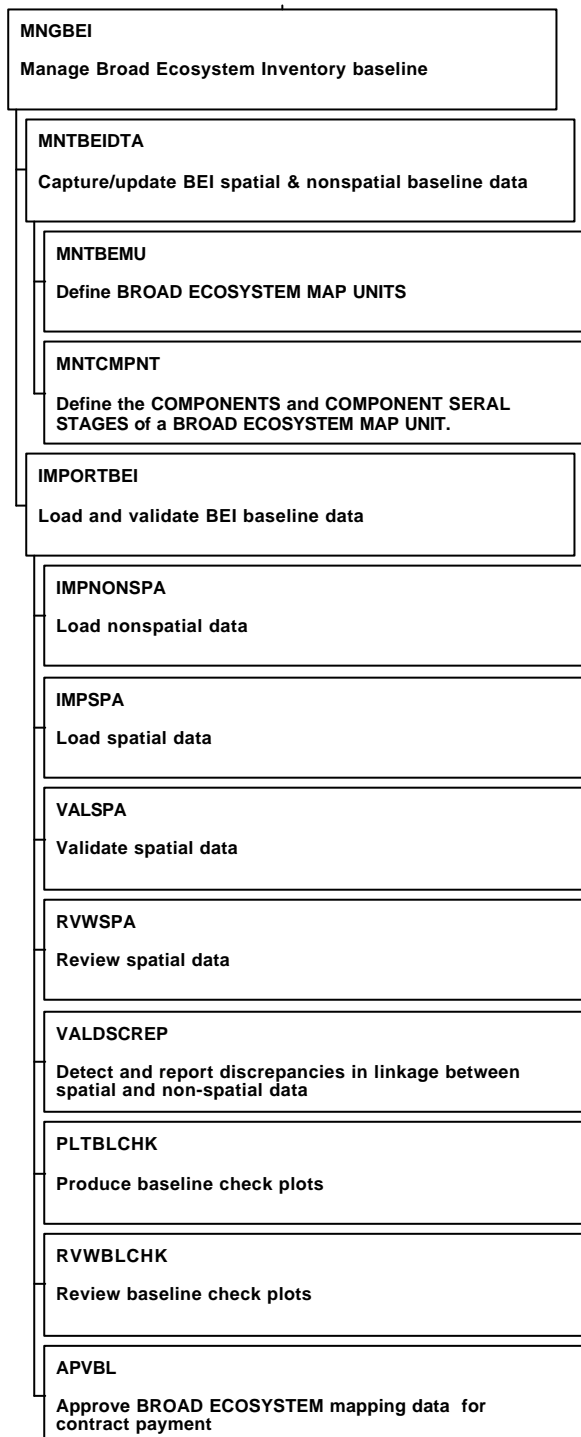

NOTE: MNTBEU and MNTCMPNT may be implemented as one function.

**Function ID:** MNTBEMU **Automated:** yes  
**Function Name:** Maintain BROAD ECOSYSTEM MAP UNIT

**Description:** Enter and maintain the BROAD ECOSYSTEM MAPPING UNIT. The data will usually be captured off-site.

**Business Unit:**

1. Mapping contractors;
2. Interpretation Unit.

**Initiating Event**

1. Captured following assembly and receipt of the project package.
2. Maintained when errors are discovered.

**Outcomes** None

**Information**

| Entity                     | Create/Read/Update/Delete |
|----------------------------|---------------------------|
| PROJECT                    | R                         |
| FEATURE MANAGEMENT EVENT   | R                         |
| ECOREGION CLASS            | R                         |
| BIOGEOCLIMATIC CLASS       | R                         |
| BIOGEOCLIMATIC UNIT        | R                         |
| ECOREGION UNIT             | R                         |
| ECOSECTION CLASS BEC RULES | R                         |
| FEATURE                    | CRUD                      |
| PROJECT FEATURE            | CRUD                      |
| BROAD ECOSYSTEM MAP UNIT   | CRUD                      |
| FEATURE DATA STATUS        | CRUD                      |

For entity attribute details see Oracle Report: Entities and their Attributes

**Metrics**

Effort:  
Function Frequency:  
Data Volume:

**Special Validations:**

1. 1 Must be at least one but not more than two components per broad ecosystem map unit, and the sum of the component deciles must = 10
2. Must be a valid combination of BEC and ECOSECTION
3. If a BEC Subzone has been subdivided into variants or phases then the BROAD ECOSYSTEM MAP UNIT must be at the same level
4. BROAD ECOSYSTEM MAP UNITS with status = "production" cannot be deleted.
5. **For the disconnected data capture/maintenance :**
  - Project number is mandatory
  - BROAD ECOSYSTEM MAP UNITS with status = "production" cannot be changed.
6. **For on-line data capture/maintenance**
  - Project number is required for "linking" project mapping meta-data. (Note: the meta data is not in scope however).

- Special Processing:**
1. When a new BROAD ECOSYSTEM MAP UNIT is created
    - Generate a new ID. The ID must be unique
    - Default the FEATURE DATA STATUS status to “work in progress” and set the status date to current date.

**For the disconnected data capture/maintenance :**

- Create a record in PROJECT FEATURE with the project/broad ecosystem map unit combination.

**For on-line data capture/maintenance :**

- If a project number is specified, create a record in PROJECT FEATURE with the project/broad ecosystem map unit combination.

- Manual Procedures**
1. The data must be captured in accordance with the standards accepted by the Ministry.
  2. The mapping contractor (external contractor or internal personnel) is responsible for ensuring integrity between the spatial and non-spatial data.
  3. A broad ecosystem map unit may cross a mapsheet boundary but must stop at the project boundary. . The mapper is responsible for ensuring that broad ecosystem map unit follows the natural boundaries (i.e. not mapsheet).
  4. The mapper must ensure that BEI units are edge matched to existing adjacent polygons in the buffered area.
  5. It is up to the mapping contractor to develop such a report that works with their own GIS environment and check for such errors prior to delivering BEI files to the Ministry. (ref. RFP page 7).

**Implementation Notes**

1. Expect to implement this function in two ways:
  - Power Objects will be used for disconnected data capture (DDC).
  - Oracle forms will be used to capture and maintain the data on-line.
2. The DDC will not have any access to BEI spatial data and will not maintain any data integrity between the spatial and non-spatial BEI data. The Ministry will not be developing a reporting program to identify where spatial/non-spatial linkage errors exist for the contractor.
3. .This process and MNTCMPT may be combined during implementation

**Outstanding Questions:**

1. None identified

**Resolved Questions:**

1. Will the ID for the Broad Ecosystem Map Unit be Ecosection Unit ID + ID. or Project + ID? Answer. The ID will be a unique system generated number. The unique identifier (aka manuscript tag) of FEATURE SPATIAL REPRESENTATION will also be a unique number for the spatial representation of the feature. The technical standards require that it be project ID + ID
2. If it is given a new ID what should happen to the old version? **Answer:** Retain it.(DC)
3. Should the BROAD ECOSYSTEM MAP UNIT be generalized to

- incorporate the DETAILED ECOSYSTEM MAP UNIT? **Answer:** No (DC)  
;although it makes sense following a review of the DEI model.
4. If the BROAD ECOSYSTEM MAP UNIT boundary changes, should the unit be given a new ID. **Answer:** Yes (DC)
  5. Can it replace more than one BROAD ECOSYSTEM MAP UNIT? **Answer:** Yes (DC)
  6. Can one BROAD ECOSYSTEM MAP UNIT be replaced by more than one at any one point? **Answer:** Yes (DC)

**Function ID:** MNTCMPNT **Automated:** yes  
**Function Name:** Maintain BROAD ECOSYSTEM COMPONENT and SERAL STAGES.

**Description:** Capture and maintain the broad ecosystem mapping unit component, its seral stages.

**Business Unit:**  
 1. Mapping Contractor.  
 2. Interpretation Unit.

**Initiated by**  
 1. When the broad ecosystem map unit has been mapped.  
 2. When errors are recognized as a result of assigning and reviewing interpretative ratings in the percent assigned.

**Outcomes**

**Information**

| Entity                                 | Create/Read/Update/Delete |
|----------------------------------------|---------------------------|
| ECOREGION CLASS                        | R                         |
| BIOGEOCLIMATIC CLASS                   | R                         |
| BROAD ECOSYSTEM CLASS                  | R                         |
| BROAD ECOSYSTEM CLASS MODIFIER         | R                         |
| SERAL STAGE CLASS                      | R                         |
| BROAD ECOSYSTEM BEC CLASS RULE         | R                         |
| BROAD ECOSYSTEM CLASS MODIFIER RULE    | R                         |
| BROAD ECOSYSTEM CLASS SERAL STAGE RULE | R                         |
| ECOREGION UNIT                         | R                         |
| BIOGEOCLIMATIC UNIT                    | R                         |
| BROAD ECOSYSTEM MAP UNIT               | R                         |
| BROAD ECOSYSTEM COMPONENT              | CRUD                      |
| BROAD ECOSYSTEM SERAL STAGE            | CRUD                      |

For entity attribute details see Oracle Report: Entities and their Attributes

**Metrics** Data Volume: 2 Components per broad ecosystem map unit  
 3 seral stages per component

**Business Rules**  
 1. For each BROAD ECOSYSTEM MAP UNIT there can be at most 2 BROAD ECOSYSTEM COMPONENTS  
 2. For each BROAD ECOSYSTEM COMPONENT there may be at most 3 BROAD ECOSYSTEM SERAL STAGES.

**Special Validations:**  
 1. The combination of BROAD ECOSYSTEM CLASS and BEC class must exist in the BROAD ECOSYSTEM CLASS BEC RULES.  
 2. If BROAD ECOSYSTEM CLASS MODIFIER is specified then the combination of BROAD ECOSYSTEM CLASS and BROAD ECOSYSTEM CLASS MODIFIER must exist in the BROAD ECOSYSTEM CLASS MODIFIER RULES.

3. The combination of BROAD ECOSYSTEM CLASS and SERAL STAGE CLASS must exist in the BROAD ECOSYSTEM CLASS SERAL STAGE RULES.
4. For each BROAD ECOSYSTEM MAP UNIT, the sum of the deciles of its components must =10, default to 10 if no decile is specified.
5. For each BROAD ECOSYSTEM COMPONENT, the sum of the deciles of its seral stages must =10 and a maximum of 3 seral stages.

**Special Processing:**

- Manual Procedures:**
1. None identified.

**Implementation Notes**

1. Expect to implement this function in two ways:
  - Power Objects will be used for disconnected data capture (DDC).
  - Oracle forms will be used to capture and maintain the data on-line.
2. This process should be combined with the previous on (Maintain BROAD ECOSYSTEM MAP UNITS) for implementation

**Outstanding Questions**

1. none

**Resolved Questions**

1. Can a BROAD ECOSYSTEM COMPONENT have more than one BROAD ECOSYSTEM CLASS MODIFIER? **Answer:** no
2. **Should** the BROAD ECOSYSTEM COMPONENT be renamed to ECOSYSTEM COMPONENT to allow the DETAILED ECOSYSTEM COMPONENT to be easily incorporated? **Answer:** No. Not unless it makes sense following the review of the DEI model..

|                             |                                                                                                                                                                                                                                                            |                   |            |
|-----------------------------|------------------------------------------------------------------------------------------------------------------------------------------------------------------------------------------------------------------------------------------------------------|-------------------|------------|
| <b>Function ID:</b>         | <b>IMPNONSPA</b>                                                                                                                                                                                                                                           | <b>Automated:</b> | <b>yes</b> |
| <b>Function Name:</b>       | <b>Import BEI non-spatial attribute data</b>                                                                                                                                                                                                               |                   |            |
| <b>Description:</b>         | Import and validate the non-spatial baseline attribute data provided by the mapping contractor into the Ministry data base.                                                                                                                                |                   |            |
| <b>Business Unit:</b>       | Cartographic Unit: GIS Technician                                                                                                                                                                                                                          |                   |            |
| <b>Initiating Events</b>    | Mapping contractor informs the Ministry that the file is on the FTP server.                                                                                                                                                                                |                   |            |
| <b>Outcomes</b>             | <ol style="list-style-type: none"> <li>1. Non-spatial data for the Broad Ecosystem Mapping Unit, component and seral stage are loaded. All have a status of “work in progress”.</li> <li>2. Error Report produced if errors in upload detected.</li> </ol> |                   |            |
| <b>External Interfaces:</b> | Non-spatial data file provided by contractor.                                                                                                                                                                                                              |                   |            |
| <b>Selection Criteria</b>   | Project Number                                                                                                                                                                                                                                             |                   |            |

**Information**

| <b>Entity</b>                             | <b>Create/Read/Update/Delete</b> |
|-------------------------------------------|----------------------------------|
| ECOREGION CLASS                           | R                                |
| BIOGEOCLIMATIC CLASS                      | R                                |
| BROAD ECOSYSTEM CLASS                     | R                                |
| BROAD ECOSYSTEM CLASS MODIFIER            | R                                |
| SERAL STAGE CLASS                         | R                                |
| BROAD ECOSYSTEM BEC CLASS RULE            | R                                |
| BROAD ECOSYSTEM CLASS MODIFIER<br>RULE    | R                                |
| BROAD ECOSYSTEM CLASS SERAL<br>STAGE RULE | R                                |
| ECOSECTION BEC CLASS RULE                 | R                                |
| ECOREGION UNIT                            | R                                |
| BIOGEOCLIMATIC UNIT                       | R                                |
| FEATURE MANAGEMENT EVENT                  | R                                |
| BROAD ECOSYSTEM MAP UNIT                  | CRUD                             |
| BROAD ECOSYSTEM COMPONENT                 | CRUD                             |
| BROAD ECOSYSTEM SERAL STAGE               | CRUD                             |
| FEATURE DATA STATUS                       | CRUD                             |
| PROJECT FEATURE                           | CRUD                             |

For entity attribute details see Oracle Report: Entities and their Attributes

|                             |                                                                                                                                                                                                                 |
|-----------------------------|-----------------------------------------------------------------------------------------------------------------------------------------------------------------------------------------------------------------|
| <b>Metrics</b>              | See the following processes: MNTBEMU                                                                                                                                                                            |
| <b>Business Rules</b>       | 1. See the following processes: MNTBEMU, MNTCMPNT                                                                                                                                                               |
| <b>Special Validations:</b> | 1. See the following processes: MNTBEMU, MNTCMPNT                                                                                                                                                               |
| <b>Special Processing:</b>  | <ol style="list-style-type: none"> <li>1. Get the contractor’s copy of the project data from the external file.</li> <li>2. Delete any existing project work broad ecosystem data from the database.</li> </ol> |

3. Upload and create new data (see MNTBEMU and MNTCMPNT for details)
4. As new data is being uploaded
  - Verify the data (see MNTBEMU and MNTCMPNT for details)
  - If an error is detected in any map unit within an Ecosection then reject the entire Ecosection and identify the error status in FEATURE DATA STATUS and on an error report
  - If not in error set FEATURE DATA STATUS status to working and status date to current date.

**Manual Procedures:** 1. If the non-attribute data backed out because of errors, the discrepancy report will identify a discrepancy in the IDs. A procedure is required to ensure the spatial data is “backed” out.

**Implementation Notes:** 1. Expect to implement using the Oracle import utility.  
2. The automated check for integrity of polygon tag between the spatial and non-spatial data is through the discrepancy report.

**Outstanding Questions:** 1. none identified

**Function ID:** IMPSPA **Automated:** Yes  
**Function Name:** Load BEI Spatial baseline Data

**Description:** Load the Broad Ecosystem spatial data created by the mapping contractor. This process does not up-load the BEC or Ecosection coverages since the business rules state they cannot be changed by the contractors. During the validation process, the broad ecosystem coverage will be overlaid with the clipped BEC and Ecosection coverages retained by the Ministry that were used for the project.

**Business Unit:** Cartographic Unit: GIS Technician

**Initiating Event:** By Ministry when mapping contractor indicates the data is available.

**Outcomes** None

**Information**

| Entity                                        | Create/Read/Update/Delete |
|-----------------------------------------------|---------------------------|
| Mylar manuscripts -ecologist map, check plots | R                         |
| Project Broad Ecosystem Coverage              | R                         |
| FEATURE MANAGEMENT EVENT                      | R                         |
| FEATURE DATA STATUS                           | CRD                       |
| FEATURE GEOMETRIC REPRESENTATION              | CRUD                      |

For entity attribute details see Oracle Report: Entities and their Attributes.

**Metrics** Frequency: 3/year  
Volume:

**Business Rules:** None

**Special Validations:** None

**Special Processing:**

1. An automated process to:
  - import the project broad ecosystem coverage into FEATURE SPATIAL REPRESENTATION (the entity representing the spatial representation of a feature such as the BROAD ECOSYSTEM MAP UNIT);
2. Ability to provide load partial amount of a project.
3. Ability to identify where a polygon is being replace by another.

**Manual Procedures:**

1. The mapping contractor is responsible for conversion from other software package formats into the ministry standard. The present standard is Arc Export single precision.
2. The mapping contractor is responsible for providing data in accordance with the standards accepted by the Ministry.
3. The mapping contractor is responsible for the integrity between the spatial and non-spatial data.
4. The project boundary should not intrude on the natural polygon boundary.
5. The mapping contractor is responsible for ensuring that polygons are not

mapsheet dependent (e.g. when a polygon crosses mapsheet, there should be only one polygon number).

6. The mapping contractor cannot change the BEC and Ecosection boundaries.

**Implementation Notes:**

1. Additional attributes required are:
  - Unique Polygon ID in the PAT table;
  - Feature codes in the AAT and PAT tables.
2. Requires access to a feature code look-up table in ARC. It will need to include:
  - symbol (lineset/colour);
  - scale;
  - description;
  - type of topology (polygon, line, point).
3. Broad ecosystem coverage will be provided by the contractor in an ArcExport file located on the FTP server.
4. This function will import the coverage into an ArcInfo polygon coverage using standard ARC utilities.
5. Must have the ability to back out changes.

**Outstanding Questions:**

1. None identified

**Process ID:** VALSPA **Automated:** Yes  
**Process Name:** Validate Spatial baseline Data

**Description:** Validate the spatial data (represented by FEATURE SPATIAL REPRESENTATION) for the BROAD ECOSYSTEM MAP UNITS to ensure it is topologically clean, the datum, projection, precision and tolerance are correct, feature codes are valid and there are no slivers.

**Business Unit:** Cartographic Unit: GIS Technician

**Initiating Event:** By Ministry when BEI coverage and associated non-spatial data are loaded.

**Outcomes** Validated coverage or coverage with errors identified.

| Entity                         | Create/Read/Update/Delete |
|--------------------------------|---------------------------|
| FEATURE SPATIAL REPRESENTATION | R                         |
| FEATURE                        | R                         |
| FEATURE MANAGEMENT EVENT       | R                         |
| FEATURE DATA STATUS            | CRD                       |
| PROJECT FEATURE                | RU                        |

For entity attribute details see Oracle Report: Entities and their Attributes

**Metrics** Frequency: 3/year  
Volume:

**Business Rules** None

**Special Edits:** 1. Must pass all validations identified in the Standards for Data Capture in a Geographic Information System of Ecosystem Inventory. Standards for Digital Terrain Data Capture.

**Special Processing:** 1. Process to:

- validate to ensure the data is topologically clean;
- check datum and projection, precision and tolerance;
- check that feature codes are valid;
- overlay submitted coverage with the original basemaps, BEC and Ecosection coverages (held in the FTP directory) and check for slivers by selecting any polygon less than the standard size. Either identify separately so they can be brought up later for visual review or halt the process. Note: some slivers may be larger than the standard polygon size and may need to be identified visually;
- Identify discrepancies between the BEC and ECOREGION identified through the spatial overlay against those recorded against the map unit in the Oracle Database. Update FEATURE DATA STATUS to identify broad ecosystem map units in error.

2. Must be able to upload a portion of a project

**Manual Procedures:** 1. None identified.

**Implementation**

**Notes:**

1. Expect to use an AML.
2. The non-spatial data must be loaded before this process can be run.

**Outstanding**

**Questions:**

1. none identified

**Resolved**

**Questions:**

1. On the non-spatial side if any Broad Ecosystem Map unit is found to be in error, then the whole Ecosection is rejected. Should this rule apply to the spatial data? Answer: **yes**

**Function ID:** RVWSPA **Automated:** Yes  
**Function Name:** Review/Correct Project Spatial Data

**Description:** Visually review the spatial data uploaded from the contractor. The review is conducted to confirm sliver errors and completeness of the ecosystem, Ecoregion etc.. If the errors are minor the Ministry may correct them, rather than return the data to the contractor

**Business Unit:** Cartographic Unit: GIS Technician

**Initiating Event:** Spatial data has been loaded, validated and plotted.

**Outcomes** None

| Information | Entity                           | Create/Read/Update/Delete |
|-------------|----------------------------------|---------------------------|
|             | FEATURE SPATIAL REPRESENTATION   | RU                        |
|             | FEATURE                          | R                         |
|             | FEATURE MANAGEMENT EVENT         | R                         |
|             | of type Broad Ecosystem Map Unit |                           |
|             | FEATURE DATA STATUS              | CRD                       |

For entity attribute details see Oracle Report: Entities and their Attributes

**Metrics**  
 Elapse Time: 2 -4 hours  
 Effort: 1 person 2 hours  
 Function Frequency: 3/year

**Business Rules** None

**Special Validations:** None

**Special Processing:**

- Set tolerances;
- Set-up edit coverage (BEU and back coverages (basemaps));
- Present an environment that will allow slivers to be corrected manually.

**Manual Procedures:** 1. Silvers may be corrected manually.

**Implementation Notes:** 1. Arc/Info built in queries are used to query polygons and visually review the polygons for silvers and completeness of the ecosystem, Ecoregion etc. .

|                             |                                                                            |                   |            |
|-----------------------------|----------------------------------------------------------------------------|-------------------|------------|
| <b>Function ID:</b>         | <b>VALDSCRDP</b>                                                           | <b>Automated:</b> | <b>yes</b> |
| <b>Function Name:</b>       | <b>Produce spatial/non spatial linkage discrepancy report</b>              |                   |            |
| <b>Description:</b>         | Detect discrepancies between related spatial and non-spatial data elements |                   |            |
| <b>Business Unit:</b>       | Cartographic Unit: GIS Technician                                          |                   |            |
| <b>Initiating Event:</b>    | 1. Spatial and non-spatial data both uploaded from contractor.             |                   |            |
| <b>Outcomes</b>             | 2. One Oracle report                                                       |                   |            |
| <b>External Interfaces:</b> | Spatial Database                                                           |                   |            |

| Information | Entity                         | Create/Read/Update/Delete |
|-------------|--------------------------------|---------------------------|
|             | PROJECT FEATURE                | R                         |
|             | FEATURE                        | R                         |
|             | BROAD ECOSYSTEM MAP UNIT       | R                         |
|             | FEATURE SPATIAL REPRESENTATION | R                         |
|             | FEATURE MANAGEMENT EVENT       | R                         |
|             | FEATURE DATA STATUS            | CRUD                      |

For entity attribute details see Oracle Report: Entities and their Attributes

|                             |                                                                                                                                                                                                                                                                                                                                                                                                                                                                                                                                                     |
|-----------------------------|-----------------------------------------------------------------------------------------------------------------------------------------------------------------------------------------------------------------------------------------------------------------------------------------------------------------------------------------------------------------------------------------------------------------------------------------------------------------------------------------------------------------------------------------------------|
| <b>Metrics</b>              | Function Frequency: One or more times per upload<br>Data Volume: Based on project                                                                                                                                                                                                                                                                                                                                                                                                                                                                   |
| <b>Business Rules</b>       | None                                                                                                                                                                                                                                                                                                                                                                                                                                                                                                                                                |
| <b>Special Validations:</b> | <ol style="list-style-type: none"> <li>1. Selection Criteria: Project</li> <li>2. For each BROAD ECOSYSTEM MAPPING UNIT there must be one and only one Broad Ecosystem Polygon in FEATURE SPATIAL REPRESENTATION</li> <li>3. For each Broad Ecosystem Polygon in FEATURE SPATIAL REPRESENTATION there must be one and only one BROAD ECOSYSTEM MAPPING UNIT.</li> </ol>                                                                                                                                                                             |
| <b>Special Processing:</b>  | <ol style="list-style-type: none"> <li>1. Select project BROAD ECOSYSTEM MAPPING UNITS from BEI non-spatial data base and project Broad Ecosystem Polygons from FEATURE SPATIAL REPRESENTATION (the entity representing the spatial database)</li> <li>2. Interrogate the polygon IDs for mismatches (see Special Validations).</li> <li>3. Detail errors on the report and update FEATURE DATA STATUS to "tag" broad ecosystem map units in error. If any map unit is found in error all map units for an Ecosystem should be rejected.</li> </ol> |
| <b>Manual Procedures:</b>   | 1. None identified.                                                                                                                                                                                                                                                                                                                                                                                                                                                                                                                                 |

**Implementation** There are \$AMLWHSE routines to do this on ISBUX2 & WLDXU2.

**Notes:**

**Outstanding  
Questions:**

1. None identified

**Function ID:** PLTBLCHK **Automated:** yes  
**Function Name:** Produce ecologists' baseline check plots

**Description:** Plot a labelled broad ecosystem unit map for the submitted area. The map may be plotted either to the screen or to a plotter for subsequent review. This process is usually performed by the BEI mapping contractor, but on occasion is done in-house.

**Business Unit:** Cartographic Unit: GIS Technician

**Initiated by** Completion of BEI mapping.

**Outcomes** Habitat values - build-in, labelling systems generation from Database.

**External Interfaces:** Oracle Database through ODBC.

**Selection Criteria** Project Number or portion of a project such as Ecosection.

#### Information

| Entity                                                                                                                                                           | Create/Read/Update/Delete |
|------------------------------------------------------------------------------------------------------------------------------------------------------------------|---------------------------|
| PROJECT                                                                                                                                                          | R                         |
| FEATURE GEOMETRIC REPRESENTATION for                                                                                                                             | R                         |
| <ul style="list-style-type: none"> <li>• Project Area</li> <li>• Biogeoclimatic Units</li> <li>• Ecoregion Units</li> <li>• Broad Ecosystem Map Units</li> </ul> |                           |
| BROAD ECOSYSTEM MAP UNIT                                                                                                                                         | R                         |
| BROAD ECOSYSTEM UNIT COMPONENT                                                                                                                                   | R                         |
| BROAD ECOSYSTEM SERAL STAGE                                                                                                                                      | R                         |

For entity attribute details see Oracle Report: Entities and their Attributes

**Metrics**  
 Effort: 1 person for 2-4 days  
 Frequency: 3x/contractor/year  
 Volume: 4 mapsheets each with ~1200 polygons

**Business Rules**  
 1. If the project area is large, then one check plot should be produced per 1:250,000 mapsheet.

**Special Validations:** None identified

**Special Processing:** A process to:  

- Access non-spatial data required for labels (e.g. components);
- Create layout cartographic elements that need to be included;
- Present Checkplot to users.

**Manual Procedures:** 1. None identified.

**Implementation  
Notes:**

1. Use an AML script to automate the process.
2. Provide check plots at source 1:250,000 mapsheet scale in UTM projection NAD83, to facilitate comparison with original manuscript.
3. Use Arc DBI to access Oracle to retrieve non-spatial attribute data required for labels.
4. The layout will be created in ArcPlot .Feature codes and symbols will be plotted to facilitate checking.
5. The checkplot will be presented in hard copy.

**Function ID:** RVWBLCHK **Automated:** no  
**Function Name:** Review ecologists' baseline check plots

**Description:** Conduct a manual scientific review of the baseline check-plots for errors. The check-plots are compared back to source maps: ecosystem, Ecoregion, biogeoclimatic.

**Business Unit:** Mapping Unit: Correlator

**Events** None

**Outcomes** Cartographic Unit informed of approval.  
 BEI returned to contractor if errors.

| Information | Entity      | Create/Read/Update/Delete |
|-------------|-------------|---------------------------|
|             | Checkplots  | R                         |
|             | Source maps | R                         |

For entity attribute details see Oracle Report: Entities and their Attributes

**Metrics** Function Frequency:  
 Data Volume:

**Business Rules** None

**Special Validations:** None

**Special Processing:** None

**Manual Procedures:** This is a manual process

**Outstanding Questions** None identified

**Function ID:** APVBL **Automated:** No  
**Function Name:** Approve BEI baseline mapping for payment

**Description:** If the submitted map file passes both the automated validation and scientific review processes, the data is approved for payment by the project correlator. The status of the approved project baseline data is changed to reflect the approval status.

**Business Unit:** Cartographic Unit

**Events** Mapping Unit review complete.

**Outcomes** BEI Baseline approved.

| Entity                   | Create/Read/Update/Delete |
|--------------------------|---------------------------|
| PROJECT                  | R                         |
| PROJECT FEATURE          | R                         |
| FEATURE                  | R                         |
| BROAD ECOSYSTEM MAP UNIT | R                         |
| FEATURE MANAGEMENT EVENT | R                         |
| FEATURE DATA STATUS      | CRUD                      |

For entity attribute details see Oracle Report: Entities and their Attributes

**Metrics** Function Frequency:  
Data Volume:

**Business Rules** None

**Special Validations:** 1. There must be no errors from the automated validation .

**Special Processing:** 1. Select the approved data  
 • For approved data change the status to “production” and update the status date.

**Manual Procedures:** 1. There map files must pass the ecologist’s scientific review

**Implementation Notes** 1. The Broad Ecosystem Map Component and Seral Stage are approved after the interpretations have been done.

**Outstanding Questions:** 1. none

**Resolved Questions:** 1. If a Broad Ecosystem Map Unit is replacing an existing unit, should the existing unit be made obsolete or deleted? Answer: Retained.  
 •

#### B.1.4.2. Manage BEI Interpretations

|                                                                                   |
|-----------------------------------------------------------------------------------|
| <b>MNGINTERP</b><br>Manage Ecosystem INTERPRETATIONS                              |
| <b>RPTDSTNCT</b><br>List DISTINCT PROVINCIAL ECOSYSTEMS                           |
| <b>MNTINTERP</b><br>Develop PROVINCIAL BEI SUITABILITY                            |
| <b>MNTSUIT</b><br>Maintain PROVINCIAL BEI SUITABILITY                             |
| <b>MNTINTALG</b><br>Maintain TAXON INTERPRETATION RULES                           |
| <b>DRVCAPAB</b><br>Calculate BROAD ECOSYSTEM INTERPRETATION                       |
| <b>PLTINTERP</b><br>Produce interpretive check plots                              |
| <b>RVWINTPLT</b><br>Review interpretive check plots                               |
| <b>MNTOVERRIDE</b><br>Override BROAD ECOSYSTEM INTERPRETATION                     |
| <b>APVDISTRIB</b><br>Approve INTERPRETATIONS and supporting data for distribution |

**Function ID:** RPTDSTNCT **Automated:** yes  
**Function Name:** List the PROVINCIAL ECOSYSTEMS

**Description:** List the distinct combinations of Ecosection, BEC, Broad Ecosystem Class, Broad Ecosystem Class Modifier for the province, or a project or Ecosection and optionally the associated provincial BEI Suitability ratings

**Business Unit:** Interpretation Unit

**Initiated by** Once the project data has been validated by the ecologists.

**Outcomes** PROVINCIAL ECOSYSTEM updated

**Information**

| Entity                      | Create/Read/Update/Delete |
|-----------------------------|---------------------------|
| PROJECT                     | R                         |
| PROJECT FEATURE             | R                         |
| FEATURE                     | R                         |
| FEATURE MANAGEMENT EVENT    | R                         |
| FEATURE DATA STATUS         | R                         |
| ORGANISM TAXON              | R                         |
| BROAD ECOSYSTEM MAP UNIT    | R                         |
| BROAD ECOSYSTEM COMPONENT   | R                         |
| BROAD ECOSYSTEM SERAL STAGE | R                         |
| PROVINCIAL BEI SUITABILITY  | R                         |

For entity attribute details see Oracle Report: Entities and their Attributes

**Metrics** Effort:  
Function Frequency:  
Data Volume:

**Business Rules** None

**Special Validations:** None

**Special Processing:** Selection Criteria: Project  
Ecosection  
Event Management Status  
Organism Taxon  
NOTE: Assume Null parameters means select all.

Sort by: Ecosection Class/Biogeoclimatic Class/Broad Ecosystem Class/Broad Ecosystem Class Modifier/Seral Stage/Taxon/Season

Options: On-line or Hard copy

**Manual Procedures:** 1. None identified

**Implementation Notes**            1. None identified

**Outstanding Questions**            1. None identified

**Function ID:** MNTINTERP **Automated:** No  
**Function Name:** Develop PROVINCIAL BEI SUITABILITY ratings

**Description:** Develop interpretative ratings through a meeting and joint discussion of branch and regional biologists. For each species being rated, a provincial benchmark for the highest rating is established. Regional biologists also identify a benchmark for their region. (This is currently not a formal process). During the joint session biologists assign ratings for each broad ecosystem unit seral stage, relative to the benchmark. The ratings are based on the characteristics of the broad ecosystem unit and those bordering it.

**Business Unit:** Region and Branch Biologists

**Initiating Event:** 1. Management Initiates Rating Process.  
2. The BEI Baseline has been validated.

**Outcomes** Suitability Ratings

**Information**

| Entity                                 | Create/Read/Update/Delete |
|----------------------------------------|---------------------------|
| ORGANISM TAXON                         | R                         |
| Benchmarks                             | R                         |
| BIOGEOCLIMATIC CLASS                   | R                         |
| ECOREGION CLASS                        | R                         |
| BROAD ECOSYSTEM CLASS                  | R                         |
| BROAD ECOSYSTEM CLASS MODIFIER         | R                         |
| SERAL STAGE CLASS                      | R                         |
| BROAD ECOSYSTEM CLASS BEC RULE         | R                         |
| BROAD ECOSYSTEM CLASS MODIFIER RULE    | R                         |
| BROAD ECOSYSTEM CLASS SERAL STAGE RULE | R                         |
| BROAD ECOSYSTEM MAP UNIT               | R                         |
| PROVINCIAL BEI SUITABILITY             | R                         |

For entity attribute details see Oracle Report: Entities and their Attributes

**Metrics**  
**Effort:** 4 people each for 3 days.  
**Frequency:** One per BEI project that involves interpretation  
**Volume:** Max. 60 species rated for the broad ecosystem units.  
Average: 10

**Business Rules** None

**Special Validations:** None

**Special Processing:** None

**Manual Procedures** This process is currently manual. Although the assignment of provincial ratings will not be streamlined at this time, the benchmark process could be more formalized

**Implementation  
Notes:**

1. Observations and benchmark entities are not in the scope of the BEI.

**Outstanding  
Questions**

1. none

**Resolved Questions**

1. Should the benchmark process be more formalized and automated support be provided? ANSWER: Yes. Should be considered as a future enhancement

**Function ID:** MNTSUIT **Automated:** yes  
**Function Name:** Maintain PROVINCIAL BEI SUITABILITYS

**Description:** Maintain the suitability rating for taxon agreed upon by the joint headquarters/regional meeting. for PROVINCIAL ECOSYSTEMS by seral stage and season

**Business Unit:** Interpretation Unit

**Initiated by** Joint Region/Branch workshop has established ratings.

**Outcomes** Provincial Suitability rating updated.

**Information**

| Entity                                 | Create/Read/Update/Delete |
|----------------------------------------|---------------------------|
| ORGANISM TAXON                         | R                         |
| ECOREGION CLASS                        | R                         |
| BIOGEOCLIMATIC CLASS                   | R                         |
| BROAD ECOSYSTEM CLASS                  | R                         |
| BROAD ECOSYSTEM CLASS MODIFIER         | R                         |
| SERAL STAGE CLASS                      | R                         |
| ECOSECTION BEC CLASS RULE              | R                         |
| BROAD ECOSYSTEM CLASS BEC RULE         | R                         |
| BROAD ECOSYSTEM CLASS MODIFIER RULE    | R                         |
| BROAD ECOSYSTEM CLASS SERAL STAGE RULE | R                         |
| INTERPRETATION CLASS                   | R                         |
| PROVINCIAL BEI SUITABILITY             | CRUD                      |

For entity attribute details see Oracle Report: Entities and their Attributes

**Metrics**  
 Effort: 1 person 3 days elapse time during the workshop  
 Frequency: 4 times per year  
 Volume:

**Business Rules** None

**Special Validations:**  
 1. The taxon must be current. (Taxon End Date must be null).  
 2. Only one classification scheme is used per species.

**Special Processing:** Default the start date

**Manual Procedures:** None

**Implementation Notes:**  
 1. Only the current provincial rating need be retained.

**Outstanding Questions:**           None

**Function ID:** MNTINTALG **Automated:** no  
**Function Name:** Maintain the TAXON INTERPRETATION RULES  
**Description:** Maintain the interpretation algorithm and classification scheme used to rate the suitability of an ecosystem for support of particular taxon.  
**Business Unit:** Interpretation Unit.  
**Initiating Events** none identified.  
**Outcomes** None

| Entity                    | Create/Read/Update/Delete |
|---------------------------|---------------------------|
| ORGANISM TAXON            | R                         |
| TAXON INTERPRETATION RULE | CRUD                      |

For entity attribute details see Oracle Report: Entities and their Attributes

**Metrics** Frequency:  
Volume:

**Business Rules** None identified

**Special Validations:** None identified

**Special Processing:** None identified

**Manual Procedures:** None identified

**Implementation Notes** The Ecosystem Scale Code defines whether the TAXON INTERPRETATION ALGORITHM RULE is for BEI or DEI.

**Outstanding Questions:**

1. Should the FEATURE INTERPRETATION (for the Broad Ecosystem Map Unit) be re-calculated if the algorithm rule is changed? If so should this be automatic?

**Function ID:** DRVCAPAB **Automated:** yes  
**Function Name:** Derive FEATURE INTERPRETATIONS

**Description:** Derive suitability ratings. for the a Broad Ecosystem Map Unit based on its seral stages.

**Business Unit:** Interpretation Unit

**Initiated by** When capability theme maps created.

**Outcomes** Suitability Rating for a broad ecosystem map unit.

**Information**

| Entity                         | Create/Read/Update/Delete |
|--------------------------------|---------------------------|
| ECOREGION CLASS                | R                         |
| BIOGEOCLIMATIC CLASS           | R                         |
| BROAD ECOSYSTEM CLASS          | R                         |
| BROAD ECOSYSTEM CLASS MODIFIER | R                         |
| SERAL STAGE CLASS              | R                         |
| ORGANISM TAXON                 | R                         |
| TAXON INTERPRETATION RULE      | R                         |
| BROAD ECOSYSTEM MAP UNIT       | R                         |
| BROAD ECOSYSTEM COMPONENT      | R                         |
| BROAD ECOSYSTEM SERAL STAGE    | R                         |
| INTERPRETATION CLASS           | R                         |
| PROVINCIAL BEI SUITABILITY     | R                         |
| FEATURE DATA STATUS            | CRUD                      |
| FEATURE INTERPRETATION         | CRUD                      |

For entity attribute details see Oracle Report: Entities and their Attributes

**Metrics** Effort:  
Frequency:  
Volume:

**Business Rules** The default algorithm used will depend on the species.

**Special Validations:** None

**Special Processing:**

1. Selection Criteria: Taxon ID, Season, Interpretation algorithm and Classification Scheme
2. Default Interpretation algorithm and Classification Scheme to the defaults for the taxon ID
3. Assign a suitability rating for the Broad Ecosystem Seral Stage based on the PROVINCIAL BEI SUITABILITY
4. Roll up the rating to the Broad Ecosystem Map Unit level. There are three roll up algorithms:
  - Weighted average. This will be the default if there is no default for

- the taxon.
  - Rating for the largest BEI component seral stage
  - Rating for the highest value seral stage
5. Set the FEATURE INTERPRETATION status and status date

**Manual Procedures** 1. None identified

**Implementation Notes** 1. None identified

**Outstanding Questions:**

1. Need to determine the algorithm of each species, if weighted average not used. **Ref Issue RFP #2** - Still to be determined.
2. What are the algorithm formulas?

**Function ID:** PLTINTERP **Automated:** yes  
**Function Name:** Produce interpretative colour-themed check-plots

**Description:** Plot the capability or suitability interpretative maps as a means of checking the assigned provincial ratings, polygon-specific ratings, and to some extent the original classification of the broad ecosystem units.

**Business Unit:** Interpretation Unit, Regions

**Initiating Event:** May be done any time.

**Outcomes** A separate interpretation theme plot, one for each species, interpretation type and season.

| Information | Entity                         | Create/Read/Update/Delete |
|-------------|--------------------------------|---------------------------|
|             | BROAD ECOSYSTEM MAP UNIT       | R                         |
|             | FEATURE SPATIAL REPRESENTATION | R                         |
|             | FEATURE INTERPRETATION         | R                         |
|             | Feature Codes                  | R                         |

For entity attribute details see Oracle Report: Entities and their Attributes

**Metrics** Elapse Time Can be several months  
 Frequency:  
 Volume:  
 If this process is performed during the joint branch/region reviews it can reduce the time taken to finalize interpretations down from months to days.

**Business Rules** None

**Special Validations:** None

**Special Processing:**

1. Selection Criteria: Interpretation Type, Species, Algorithm type, Season and geographic area.
2. A process to automatically produce a colour-themed map for screen or plot based on the selection criteria. The map should include: title (suitability or capability for a specified species), scale, key with classes, reference grid, source, and map area.

**Manual Procedures:** 1. None identified

**Implementation Notes:**

1. This process should be capable of plotting either to the screen or to a plotter.
2. It is anticipated that this process would be implemented using the Ministry's GOAT or ArcView
3. An AML (or Avenue Script for GOAT) will be used to automate the process.

**Outstanding** 1. None identified

**Questions:**

**Function ID:** RVWINTPLT **Automated:** no  
**Function Name:** Review interpretative ratings via check-plots  
**Description:** Review of the interpretative check-plots by branch and region biologists.  
**Business Unit:** Interpretation Unit: Head Office and Branch biologists.  
**Initiating Events** Interpretative check plots produced from joint branch/region workshop.  
**Outcomes** None

| Entity                     | Create/Read/Update/Delete |
|----------------------------|---------------------------|
| Interpretation Theme Plots | R                         |

For entity attribute details see Oracle Report: Entities and their Attributes

**Metrics** Elapse time  
Frequency:  
Volume:  
**Business Rules** None  
**Special Validations:** None  
**Special Processing:** None  
**Manual Procedures:** None identified  
**Implementation Notes** None  
**Outstanding Questions:** None identified

**Function ID:** MNTOVERRIDE **Automated:** yes  
**Function Name:** Maintain Broad Ecosystem Unit interpretative rating over-rides.

**Description:** Enter an over-ride interpretative rating for the BROAD ECOSYSTEM MAP UNIT. This is done only when the provincial rating is not appropriate for a particular unit.

**Business Unit:** Interpretation Unit

**Initiated by** When the provincial rating does not apply.

**Outcomes** None

**Information**

| Entity                         | Create/Read/Update/Delete |
|--------------------------------|---------------------------|
| TAXON INTERPRETATION RULE      | R                         |
| INTERPRETATION CLASS           | R                         |
| BROAD ECOSYSTEM MAP UNIT       | R                         |
| BROAD ECOSYSTEM COMPONENT      | R                         |
| BROAD ECOSYSTEM SERAL STAGE    | R                         |
| FEATURE SPATIAL REPRESENTATION | R                         |
| FEATURE INTERPRETATION         | CRUD                      |

For entity attribute details see Oracle Report: Entities and their Attributes

**Metrics** Effort:  
Frequency:  
Volume:

**Business Rules** 1. An over-ride is only provided when the provincial rating is not appropriate.

**Special Validations:**

**Special Processing:** 1. None identified

**Manual Procedures:** 1. None identified

**Implementation Notes:** 1. The first rating is generated by the system. The second rating is a manual over-ride.

**Outstanding Questions:** 1. Will Regions be entering the override? (LL)

**Function ID:** APVDISTRIB **Automated:** no  
**Function Name:** Approve the INTERPRETATIONS and reference data for distribution

**Description:** Approve the FEATURE INTERPRETATION data for distribution.

**Business Unit:** Interpretation Unit.

**Initiating Events** Interpretations are complete for a project or portion of a project (e.g. Ecosection)

**Outcomes** None

**Information**

| Entity                      | Create/Read/Update/Delete |
|-----------------------------|---------------------------|
| PROJECT FEATURE             | R                         |
| FEATURE                     | R                         |
| ECOREGION UNIT              | R                         |
| BROAD ECOSYSTEM MAP UNIT    | R                         |
| BROAD ECOSYSTEM COMPONENT   | R                         |
| BROAD ECOSYSTEM SERAL STAGE | R                         |
| FEATURE INTERPRETATION      | CRUD                      |
| FEATURE MANAGEMENT EVENT    | R                         |
| FEATURE DATA STATUS         | CRUD                      |

For entity attribute details see Oracle Report: Entities and their Attributes

**Metrics** Elapse time  
Frequency:  
Volume:

**Business Rules** None

**Special Validations:** None

**Special Processing:**

1. Selection by Project or portion of a project such as Ecosection
2. Set the STATUS OF THE FEATURE INTERPRETATION
3. Set THE FEATURE DATA STATUS of the BROAD ECOSYSTEM MAP UNIT status to production and status to current date

**Manual Procedures:** None identified

**Implementation Notes** None

**Outstanding Questions:** None identified

**B.1.5. Use BEI Data**

**Business Function Hierarchy**

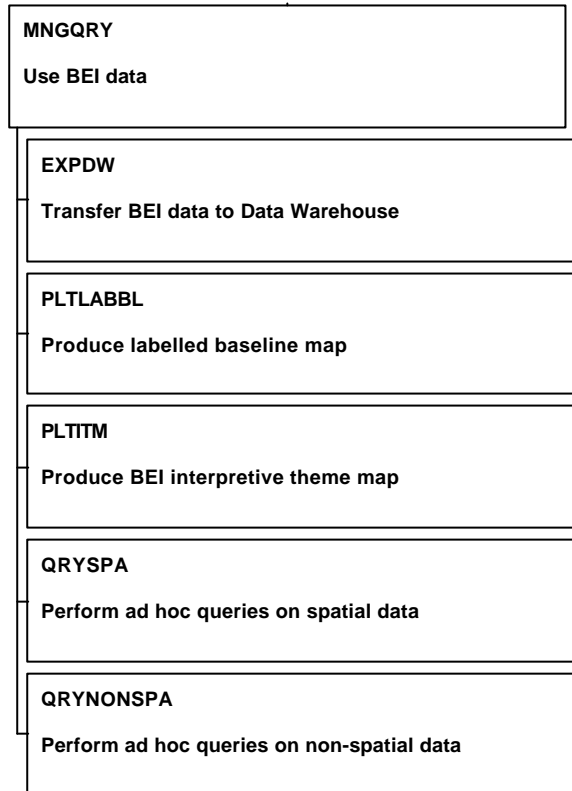

|                       |                                                                                                                                                                             |                   |     |
|-----------------------|-----------------------------------------------------------------------------------------------------------------------------------------------------------------------------|-------------------|-----|
| <b>Process ID:</b>    | <b>EXPDW</b>                                                                                                                                                                | <b>Automated:</b> | yes |
| <b>Process Name:</b>  | <b>Transfer BEI data to Wildlife Data Warehouse</b>                                                                                                                         |                   |     |
| <b>Description:</b>   | Transfer the approved published BEI data into the Wildlife data warehouse on a periodic basis. Entire coverages are transferred to the Wildlife and Master Data Warehouses. |                   |     |
| <b>Business Unit:</b> | Data Warehouse Administrator and Headquarters Cartographic Unit.                                                                                                            |                   |     |
| <b>Initiated by</b>   | On demand by Cartographic Unit.                                                                                                                                             |                   |     |
| <b>Outcomes</b>       | Data warehouse populated.                                                                                                                                                   |                   |     |

**Information**

| <b>Entity</b>                  | <b>Create/Read/Update/Delete</b> |
|--------------------------------|----------------------------------|
| BROAD ECOSYSTEM MAP UNIT       | R                                |
| BROAD ECOSYSTEM COMPONENT      | R                                |
| BROAD ECOSYSTEM SERAL STAGE    | R                                |
| PROVINCIAL BEI SUITABILITY     | R                                |
| FEATURE INTERPRETATION         | R                                |
| ORGANISM TAXON                 | R                                |
| TAXON SYNONYM                  | R                                |
| TAXON ADHOC GROUP              | R                                |
| FEATURE SPATIAL REPRESENTATION | R                                |

For entity attribute details see Oracle Report: Entities and their Attributes

|                            |                                                                                                                                                                                                                                                                                                                                                                                                                                                                                                                                                                                                                                                                                                                  |
|----------------------------|------------------------------------------------------------------------------------------------------------------------------------------------------------------------------------------------------------------------------------------------------------------------------------------------------------------------------------------------------------------------------------------------------------------------------------------------------------------------------------------------------------------------------------------------------------------------------------------------------------------------------------------------------------------------------------------------------------------|
| <b>Metrics</b>             | Effort: Scheduled batch jobs to be run in non-prime time.<br>Frequency: 2 times/year<br>Volume: 2.5GB potential                                                                                                                                                                                                                                                                                                                                                                                                                                                                                                                                                                                                  |
| <b>Business Rules</b>      | 1. Transfer on approval by Habitat Terrestrial Species Inventory manager.                                                                                                                                                                                                                                                                                                                                                                                                                                                                                                                                                                                                                                        |
| <b>Special Edits:</b>      | 1. Load records will be time stamped to maintain uniqueness.                                                                                                                                                                                                                                                                                                                                                                                                                                                                                                                                                                                                                                                     |
| <b>Special Processing:</b> | <ol style="list-style-type: none"> <li>1. Automate attribute/spatial data warehouse updates to maintain data timeliness.</li> <li>2. Data load verification. Load process log reports will be maintained and available for scheduled review by administrators to ensure the load process was successful.</li> <li>3. Transfer the new coverage to the data warehouse.</li> <li>4. Takes snapshot non-spatial published BEI data and transfer to the warehouse.</li> <li>5. An additional column will be added to the BEI Data Warehouse tables to indicate whether each record is in a Preliminary or Final state, i.e. still under review or published. Under review data would be used at own risk.</li> </ol> |
| <b>Manual Procedures</b>   | 1. none identified.                                                                                                                                                                                                                                                                                                                                                                                                                                                                                                                                                                                                                                                                                              |
| <b>Implementation</b>      | 1. This process will be implemented using the Data Registry Application.                                                                                                                                                                                                                                                                                                                                                                                                                                                                                                                                                                                                                                         |

**Notes**

2. The intent will be to have users make use of seamless province-wide coverages. If this is found to be technically or logistically inappropriate, sub-provincial or regional coverages may be necessary.
3. Suggestions will be made for testing adhoc regional cutouts and queries as regional users desire this ability. If this capability does not fit within the Master Data Warehouse mandate, a simple web interface to the Wildlife Production Warehouse could provide the regions with the ability to define the information they want and either download via HTML forms or bulk FTP transfer and then loaded/imported into their local Oracle/ESRI databases. This will allow authorized regional offices, contractors and agencies to create their own customised workfile.
4. Assume that other coverages (e.g. BEC, Ecosection and NTS, mapsheet and administrative region) are already in the warehouse.

**Outstanding Questions:**

None identified

**Resolved Questions:** None

|                             |                                                                                           |                   |     |
|-----------------------------|-------------------------------------------------------------------------------------------|-------------------|-----|
| <b>Function ID:</b>         | <b>PLTLABBL</b>                                                                           | <b>Automated:</b> | yes |
| <b>Function Name:</b>       | <b>Produce labelled BEI baseline map</b>                                                  |                   |     |
| <b>Description:</b>         | Plot a labelled broad ecosystem inventory baseline map with map surround, legend(s) etc.. |                   |     |
| <b>Business Unit:</b>       | Regions, Headquarters, Contracts, Clients                                                 |                   |     |
| <b>Initiated by</b>         | As required.                                                                              |                   |     |
| <b>Outcomes</b>             | Hardcopy & Digital labelled maps.                                                         |                   |     |
| <b>External Interfaces:</b> | LDBC, MELP Data Registry, Website (FTP).                                                  |                   |     |
| <b>Selection Criteria</b>   | By Mapsheet and Project area.                                                             |                   |     |

**Information**

| Entity                         | Create/Read/Update/Delete |
|--------------------------------|---------------------------|
| BROAD ECOSYSTEM MAP UNIT       | R                         |
| BROAD ECOSYSTEM COMPONENT      | R                         |
| BROAD ECOSYSTEM SERAL STAGE    | R                         |
| FEATURE INTERPRETATION         | R                         |
| FEATURE SPATIAL REPRESENTATION | R                         |
| for                            |                           |
| • BIOGEOCLIMATIC UNIT          |                           |
| • ECOREGION UNIT               |                           |
| • BROAD ECOSYSTEM MAP UNIT     |                           |

For entity attribute details see Oracle Report: Entities and their Attributes

|                |                                                                  |
|----------------|------------------------------------------------------------------|
| <b>Metrics</b> | Effort:<br>Frequency: During each map update project.<br>Volume: |
|----------------|------------------------------------------------------------------|

|                       |      |
|-----------------------|------|
| <b>Business Rules</b> | None |
|-----------------------|------|

|                             |                                                                                                                                                                                                                                                                                                                                                                               |
|-----------------------------|-------------------------------------------------------------------------------------------------------------------------------------------------------------------------------------------------------------------------------------------------------------------------------------------------------------------------------------------------------------------------------|
| <b>Special Validations:</b> | <ol style="list-style-type: none"> <li>1. The legend will indicate scale, mapsheet area, symbology, feature codes, projection (Albers Conformal Conic), units (meters), logo, disclaimer, datum (NAD 83 CNT) and direction.</li> <li>2. The map borders will indicate Lat/Long, or UTM, and zone. Map surround will be uniform to the standards of Geographic B.C.</li> </ol> |
|-----------------------------|-------------------------------------------------------------------------------------------------------------------------------------------------------------------------------------------------------------------------------------------------------------------------------------------------------------------------------------------------------------------------------|

|                            |                                                                                                                                                                                                                                        |
|----------------------------|----------------------------------------------------------------------------------------------------------------------------------------------------------------------------------------------------------------------------------------|
| <b>Special Processing:</b> | <ol style="list-style-type: none"> <li>1. Access non-spatial data required for labels (e.g. Tag).</li> <li>2. Create layout cartographic elements that need to be included: Surround AML.</li> <li>3. Present map to users.</li> </ol> |
|----------------------------|----------------------------------------------------------------------------------------------------------------------------------------------------------------------------------------------------------------------------------------|

|                           |                     |
|---------------------------|---------------------|
| <b>Manual Procedures:</b> | 1. none identified. |
|---------------------------|---------------------|

**Implementation**

**Notes:**

1. The maps will be designed and produced via ArcPlot/ArcView + AML Avenue.
2. The display mechanism will be GOAT or ARC/Info Workstation.

**Outstanding**

**Questions:**

1. None identified

|                          |                                                                        |                   |     |
|--------------------------|------------------------------------------------------------------------|-------------------|-----|
| <b>Function ID:</b>      | <b>PLTITM</b>                                                          | <b>Automated:</b> | Yes |
| <b>Function Name:</b>    | <b>Produce interpretative maps</b>                                     |                   |     |
| <b>Description:</b>      | Plot the wildlife capability or suitability interpretative theme maps. |                   |     |
| <b>Business Unit:</b>    | Regions and Headquarters Cartographic Units, Contractors and Clients.  |                   |     |
| <b>Initiating Event:</b> | May be done at any time.                                               |                   |     |
| <b>Outcomes</b>          | A separate interpretation theme map, one for each Wildlife species.    |                   |     |

**Information**

| Entity                         | Create/Read/Update/Delete |
|--------------------------------|---------------------------|
| ORGANISM TAXON                 | R                         |
| FEATURE INTERPRETATION         | R                         |
| BROAD ECOSYSTEM MAP UNIT       | R                         |
| BROAD ECOSYSTEM COMPONENT      | R                         |
| BROAD ECOSYSTEM SERAL STAGE    | R                         |
| FEATURE INTERPRETATION         | R                         |
| FEATURE SPATIAL REPRESENTATION | R                         |
| for                            |                           |
| • BIOGEOCLIMATIC UNIT          |                           |
| • ECOREGION UNIT               |                           |
| • BROAD ECOSYSTEM MAP UNIT     |                           |

For entity attribute details see Oracle Report: Entities and their Attributes

|                              |                                                                                                                                                                                                                                                                                                                                                                                                           |
|------------------------------|-----------------------------------------------------------------------------------------------------------------------------------------------------------------------------------------------------------------------------------------------------------------------------------------------------------------------------------------------------------------------------------------------------------|
| <b>Metrics</b>               | Function Frequency<br>Data Volume                                                                                                                                                                                                                                                                                                                                                                         |
| <b>Business Rules</b>        | 1. Wildlife species ratings and logic must be to Headquarters standards.                                                                                                                                                                                                                                                                                                                                  |
| <b>Special Validations:</b>  | None                                                                                                                                                                                                                                                                                                                                                                                                      |
| <b>Special Processing:</b>   | <ol style="list-style-type: none"> <li>1. Selection Criteria: Provincial Ecosystem, Interpretation Type, Taxon ID, Season</li> <li>2. A process to automatically produce a colour-themed map for screen or plot based on the selection criteria</li> <li>3. The maps will use the provincial standard tiling scheme and will be presented seamlessly</li> <li>4. Allocate colour rating scheme</li> </ol> |
| <b>Implementation Notes:</b> | <ol style="list-style-type: none"> <li>1. BEU maps will include up to six individual <i>member units</i>: 2 BEU/modifier combinations with up to 3 seral stages each.</li> <li>2. Standard Algorithms according to species will be used to derive ratings. The Algorithm, logic rules and classification scheme used will be recorded as part of the map legend.</li> </ol>                               |

3. The map will indicate the species name, interpretation type and rating, the presentation method, scale, reference grid, colour/graphics legend to interpretative ratings - to be standard across all maps and all areas of the province.
4. The maps will be designed and produced via ArcView.
5. The display mechanism will be GOAT as Arc/View 3.0 will be able to handle 1:250,000 map plots and interfaces to Oracle.

**Outstanding Questions:**

1. Generalized Ecosystem handling?
2. Map display issue: - Dithering or Combinations or other. Mappers must delineate components as data is collected to clarify map presentation.? RFD #2 still to be determined.

| <b>Function ID:</b>           | <b>QRYSQA</b>                                                                                                                                                                                                                                                                                                              | <b>Automated:</b> | yes |        |                           |  |  |
|-------------------------------|----------------------------------------------------------------------------------------------------------------------------------------------------------------------------------------------------------------------------------------------------------------------------------------------------------------------------|-------------------|-----|--------|---------------------------|--|--|
| <b>Function Name:</b>         | <b>Perform adhoc spatial query tests.</b>                                                                                                                                                                                                                                                                                  |                   |     |        |                           |  |  |
| <b>Description:</b>           | Perform ad hoc queries on spatial data.                                                                                                                                                                                                                                                                                    |                   |     |        |                           |  |  |
| <b>Business Unit:</b>         | Headquarters Cartographic Units.                                                                                                                                                                                                                                                                                           |                   |     |        |                           |  |  |
| <b>Initiating Event</b>       | As required.                                                                                                                                                                                                                                                                                                               |                   |     |        |                           |  |  |
| <b>Outcomes</b>               | To be defined by query.                                                                                                                                                                                                                                                                                                    |                   |     |        |                           |  |  |
| <b>External Interfaces:</b>   | None                                                                                                                                                                                                                                                                                                                       |                   |     |        |                           |  |  |
| <b>Selection Criteria</b>     | To be defined by query. Potential queries could include Ecosection, BEI project boundary, BEC zone, BEC sub-zone, BEC variant, BEC phase and 1:250,000 BEI polygons.                                                                                                                                                       |                   |     |        |                           |  |  |
| <b>Information</b>            | <table border="1" style="width: 100%; border-collapse: collapse;"> <thead> <tr style="background-color: #cccccc;"> <th style="text-align: left;">Entity</th> <th style="text-align: right;">Create/Read/Update/Delete</th> </tr> </thead> <tbody> <tr> <td style="height: 20px;"> </td> <td> </td> </tr> </tbody> </table> |                   |     | Entity | Create/Read/Update/Delete |  |  |
| Entity                        | Create/Read/Update/Delete                                                                                                                                                                                                                                                                                                  |                   |     |        |                           |  |  |
|                               |                                                                                                                                                                                                                                                                                                                            |                   |     |        |                           |  |  |
|                               | For entity attribute details see Oracle Report: Entities and their Attributes                                                                                                                                                                                                                                              |                   |     |        |                           |  |  |
| <b>Metrics</b>                | Effort:<br>Function Frequency:<br>Data Volume:                                                                                                                                                                                                                                                                             |                   |     |        |                           |  |  |
| <b>Business Rules</b>         | None.                                                                                                                                                                                                                                                                                                                      |                   |     |        |                           |  |  |
| <b>Special Validations:</b>   | None.                                                                                                                                                                                                                                                                                                                      |                   |     |        |                           |  |  |
| <b>Special Processing:</b>    | None                                                                                                                                                                                                                                                                                                                       |                   |     |        |                           |  |  |
| <b>Manual Processing:</b>     | None                                                                                                                                                                                                                                                                                                                       |                   |     |        |                           |  |  |
| <b>Implementation Notes:</b>  | <ol style="list-style-type: none"> <li>1. Customize the existing ARC GUI if required to ease querying of EI spatial data warehouse.</li> </ol> <p>Results will be displayed via GOAT.</p>                                                                                                                                  |                   |     |        |                           |  |  |
| <b>Outstanding Questions:</b> | None                                                                                                                                                                                                                                                                                                                       |                   |     |        |                           |  |  |

**Function ID:** QRYNONSPA **Automated:** yes  
**Function Name:** Perform adhoc non-spatial query tests

**Description:** There are currently no standard non-spatial queries or reports defined.

**Business Unit:** Headquarters Cartographic Units

**Initiated by** As required.

**Outcomes** To be defined by query.

**External Interfaces:** None

**Selection Criteria** To be defined by query.

|                    |               |                                  |
|--------------------|---------------|----------------------------------|
| <b>Information</b> | <b>Entity</b> | <b>Create/Read/Update/Delete</b> |
|                    |               |                                  |

**Metrics**  
 Effort:  
 Frequency: As required  
 Volume:

**Business Rules** None

**Special Validations:** None

**Special Processing:** None

**Manual Procedures:** None identified

**Implementation Notes:** EI report formats will be suggested for listing contents of the non-spatial data with potential alternatives indicated.

Implement a user friendly interface to ease querying of EI spatial data warehouse with standard ARC toolset. These will enable adhoc inquiries based on the needs of the user.

Queries will be implemented via standard Oracle tools. Printed reports will interface to the Ministry's UNIX Print Utility.

1. Potential queries include Taxa or Ecoadmin by interpretation rating, Ecosession, BEC climate, BEI, BEI modifiers and Seral Stage classes. In addition queries could be based on project details or BEI data administration and flow.

**Outstanding Questions:**  
 2. none

**B.2. DISCONNECTED DATA CAPTURE**

For business function requirements see Manage BEI:

- Maintain Broad Ecosystem Map Unit
- Maintain Broad Ecosystem Component and Seral Stages

### **B.3. BEI TECHNICAL STANDARDS DOCUMENT**

#### **B.3.1. High-Level Specifications**

##### ***B.3.1.1.Objectives of Standards Document:***

- Aid contractors to understand ecosystem inventory data capture process;
- Define, to contractors, the exact requirements for data returned to Ministry;
- Aid technical users to understand the data.

##### ***B.3.1.2.Scope***

The following business functions are to be reflected in the standards document:

- Receipt of baseline mapping data process by contractor;
- data capture rules for BEI data
- QA of captured data process by contractor is not an issue for BEI data. This will become important for DEI data;
- delivery format and process from contractor to MELP;
- Detailed ArcInfo spatial standards are required to accompany the non-spatial disconnected data capture application. The document will detail coverages, symbology, feature codes, delivery methods, etc. for contractors who conduct BEI mapping for the Wildlife Program.

##### ***B.3.1.3.Table of Contents***

1. Introduction;
2. Disconnected Data Capture Application Discussion (*should include delivery method, attributes, descriptions etc.*);
3. DDC Application Documentation;
4. Digital Data Specifications for BEI Mapping in GIS;
5. Check Plots
6. Metadata
7. Delivery
8. BEI Entity Relationship Diagrams (ERDs) and Associated Data Dictionary (*show broad relationship diagram for entire BEI project*);
9. Additional Information Documentation.

**B.3.1.4. Requirements Identified**

- Coverage (BEU):
  - polygon and arc feature types;
- Name conventions (use MELP stds):
  - chars (DOS), scale+content\_extent (e.g.: qbec\_82g);
- Feature codes (arc (AAT) and polygon (PAT)):
  - assign to arcs and polygon labels;
  - provide list of appropriate fcodes;
- Symbology:
  - provide table of specifications for symbology & URL to A/I symbols;
  - not scale dependent;
- Data quality:
  - lineage (data set sources, feature resolution or source scale);
  - processing tolerances (fuzzy, weed, dangle) ;
  - (need to determine tolerances as there are no Ministry standards at this time);
  - co-ordinate storage precision (single = 7 decimal digits preserved);
- Spatial co-ordinate system (use MELP standard):
  - projection (Albers Conformal Conic);
  - units (meters);
  - datum (NAD 83 CNT);
- Topology:
  - types polygon and arc, must be built;
  - contiguity (fnode, tnode, lpoly, rpoly);
  - no open polygons, no dangles, no pseudo-nodes, no excess vertices (use MELP std), no label errors, no slivers;
- Attribute definition:
  - definitions for spatial attributes: covername\_tag and fcodes;
  - definitions for non-spatial attributes;
  - include data dictionary (spatial and non-spatial);
- Polygon identification:
  - use standard ministry conventions (projectid+polygon# or map#+poly#);
- Delivery methods:
  - OUT: (to contractor);
  - Arc export files on ftp;
  - files (BEC polygons, Ecosection polygons, Water bodies arcs and polygons, and Project boundary polygon as exported coverage files) (keep the features

separate for the contractor so that translation into a different GIS will be easier);

- IN: (to MELP);
- Arc export file to ftp;
- 1 file (BEU polygon exported coverage file);
- Metadata:
  - metadata to stored with each Arc coverage (stored in INFO using document.aml for metadata content) (issue: at what stage will metadata get input to coverage?);
  - metadata also held in Data Registry (one entry for BEI data).
- Check Plot Information and Rules

***B.3.1.5. Identified Deliverables format and content:***

- MS Word Document;
- copy format, content of ‘Terrain Standards Manual’ where appropriate.

**B.4. GLOSSARY OF TERMS**

|                              |                                                                                                                                                                                                                                                                                                                                                                                                                    |
|------------------------------|--------------------------------------------------------------------------------------------------------------------------------------------------------------------------------------------------------------------------------------------------------------------------------------------------------------------------------------------------------------------------------------------------------------------|
| <b>ArcEdit:</b>              | ARCEDIT is ARC/INFO's program for editing coverage coordinate and attribute data. It provides the tools necessary for creating and maintaining geographic databases.                                                                                                                                                                                                                                               |
| <b>ArcInfo:</b>              | is a geographic information system with tools for automation, analysis, display, and management of geographic information. It was developed and is supported by Environmental Systems Research Institute, (ESRI), of Redlands, California.                                                                                                                                                                         |
| <b>ArcPlot:</b>              | provides the cartographic tools for ARC/INFO mapping, including layout and design, data selection, data display, feature symbolization and labelling, cartographic additions, graphics import and other plotting processes.                                                                                                                                                                                        |
| <b>BEC</b>                   | Biogeoclimatic Ecosystem Classification. BEC units represent classes of ecosystems under the influence of the same regional climate.                                                                                                                                                                                                                                                                               |
| <b>BEI:</b>                  | Broad Ecosystem Inventory. Generalized (broad) description of ecosystems at 1:250,000 scale.                                                                                                                                                                                                                                                                                                                       |
| <b>BEI Project:</b>          | A mapping project. See Project below.                                                                                                                                                                                                                                                                                                                                                                              |
| <b>Biogeoclimatic zones:</b> | Large geographic areas with a broadly homogeneous macroclimate. There are 14 biogeoclimatic zones in the province.                                                                                                                                                                                                                                                                                                 |
| <b>Broad:</b>                | Refers to the scale of mapping activity, namely 1:250,000.                                                                                                                                                                                                                                                                                                                                                         |
| <b>Capability:</b>           | The potential carrying capacity of an area of land for a given wildlife species assuming the vegetation of the area is maintained in its most productive successional stage for that species.                                                                                                                                                                                                                      |
| <b>Contractor(s):</b>        | The appointed/selected consultants that will collect and capture the spatial and attribute (non-spatial) Broad Ecosystem Unit data.                                                                                                                                                                                                                                                                                |
| <b>Coverage :</b>            | The coverage is a method for storing point, line, and area geographic features. A database will typically contain several coverages, each representing a single set of geographic features such as roads, parcels, soil units, or forest stands in a given area. The coverage supports the georelational model -- it contains both the spatial (location) and attribute(descriptive) data for geographic features. |

|                            |                                                                                                                                                                                                                                                                                 |
|----------------------------|---------------------------------------------------------------------------------------------------------------------------------------------------------------------------------------------------------------------------------------------------------------------------------|
| <b>Coverage Feature</b>    | Feature classes are used on the coverage for storing real-world geographic features represented as points, lines, or areas. They include points for storing features, arc, node, and route-system of storing linear features and polygon and region for storing areal features. |
| <b>CRUDA</b>               | Create, Review, Update, Delete, Archive.                                                                                                                                                                                                                                        |
| <b>Data Registry:</b>      | An Oracle Forms 4.5.6 application that will enable application metadata to be recorded together with database table, column and constraint information that will be used for the automatic transformation and replication to the data warehouse.                                |
| <b>Data Warehouse:</b>     | A static, consolidated database containing data gathered from various production applications, into a corporate or regional data repository for ad hoc read only access to business data, integrating as appropriate attribute and spatial data.                                |
| <b>DEI:</b>                | Detailed Ecosystem Inventory. The detailed description of ecosystems at 1:5000 to 1:50,000 scales.                                                                                                                                                                              |
| <b>Disconnected</b>        | A self contained executable module that contains imbedded data                                                                                                                                                                                                                  |
| <b>Data Capture:</b>       | validation to enable the contractors to capture Broad Ecosystem Unit polygon attribute data.                                                                                                                                                                                    |
| <b>Ecoregion:</b>          | is an area with major physiographic and minor macroclimatic or oceanographic variation. There are 43 Ecoregions in the province of which 39 are terrestrial.                                                                                                                    |
| <b>Ecosection:</b>         | is an area with minor physiographic and macroclimatic or oceanographic variation. There are 110 Ecosections in the province of which 100 are terrestrial. This is the unit used in ecosystem mapping at two scales of presentation 1:2,000,000 and 1:250,000 (see p. 20).       |
| <b>Ecosystem Mapping:</b>  | provides a taxonomic framework used for describing the nature and pattern of ecological units within a landscape. Ecosystem mapping depicts the actual spatial distribution of ecological (ecosystem) units.                                                                    |
| <b>Ecosystem Map Unit:</b> | broad-level geographic areas based on the integration of vegetation, terrain (surficial material), topography and soil characteristics.                                                                                                                                         |
| <b>ERD:</b>                | Entity Relationship Diagram produced from Oracle Designer/2000.                                                                                                                                                                                                                 |
| <b>FK:</b>                 | Foreign Key.                                                                                                                                                                                                                                                                    |

|                              |                                                                                                                                                                                                                                                                                                                                                                                                                                                                          |
|------------------------------|--------------------------------------------------------------------------------------------------------------------------------------------------------------------------------------------------------------------------------------------------------------------------------------------------------------------------------------------------------------------------------------------------------------------------------------------------------------------------|
| <b>FPC:</b>                  | Forest Practices Code.                                                                                                                                                                                                                                                                                                                                                                                                                                                   |
| <b>FRBC:</b>                 | Forest Renewal BC.                                                                                                                                                                                                                                                                                                                                                                                                                                                       |
| <b>Geographic attributes</b> | Usually refers to textual and other non-spatial descriptors associated with geographic features.                                                                                                                                                                                                                                                                                                                                                                         |
| <b>GOAT:</b>                 | The BC Environment GIS and Oracle Access Tool (GOAT) was created for simple viewing, reporting, querying, and plotting of geographic and associated attribute data from a desktop computer.                                                                                                                                                                                                                                                                              |
| <b>GIS:</b>                  | Geographic Information System. A system for capturing, storing, checking, integrating, analyzing and displaying data about the earth that is spatially referenced. It is normally taken to include a spatially referenced data base and appropriate applications software.                                                                                                                                                                                               |
| <b>LAN:</b>                  | Local area network.                                                                                                                                                                                                                                                                                                                                                                                                                                                      |
| <b>LPM:</b>                  | Logical Process Model.                                                                                                                                                                                                                                                                                                                                                                                                                                                   |
| <b>LRMP:</b>                 | Land Resource Management Plan/Planning.                                                                                                                                                                                                                                                                                                                                                                                                                                  |
| <b>Oracle Power Objects:</b> | A component of the Oracle toolset that allows the development of self contained modules.                                                                                                                                                                                                                                                                                                                                                                                 |
| <b>Operational:</b>          | Detailed level of planning aimed at field level activities.                                                                                                                                                                                                                                                                                                                                                                                                              |
| <b>Polygon</b>               | Closed areas that represent the shape and location of homogeneous features such as states, counties, parcels, soil types, or land use zones. Each polygon has a unique identifier used to identify the polygon on a map and to associate the attribute data from the Oracle database.                                                                                                                                                                                    |
| <b>Project:</b>              | In the Wildlife context a project is uniquely identified activity usually contracted-out that relates to a demarcated section of the province for the purposes of collecting data.<br><br>In the context of this assignment, there are two “projects”, the: <ul style="list-style-type: none"> <li>• BEI Project which includes the Mid-Coast mapping/re-mapping and LRMP planning; and</li> <li>• BEI Database Development project to which this RFP refers.</li> </ul> |
| <b>Prototype :</b>           | The development of a test module or application to prove its acceptability and viability.                                                                                                                                                                                                                                                                                                                                                                                |
| <b>Region:</b>               | The region feature class was developed to handle overlapping area data more efficiently. Regions can also handle                                                                                                                                                                                                                                                                                                                                                         |

discontinuous and nested areas. Because they are organized by subclass, regions permit thematic data to be integrated into a single coverage.

- Strategic :** Overview level of planning used mainly for allocations with reference to login planning, etc..
- Suitability:** The potential carrying capacity of an area of land for a given wildlife species based upon the vegetation's current successional stage.
- Topology** Relationship between spatial objects defined by their boundaries, irrespective of absolute position and extent. Typically expressed by the terms : adjacent, intersecting, disjoint, enclosing, connecting.
- Taxonomic Code:** A code used to represent a particular organism taxon at any level in the scientific taxonomic classification system.
- UID** Unique Identifier. One or more attributes that uniquely identify an entity.
- 1:250,000:** The scale of data capture used for Broad Ecosystem Inventory mapping.

**B.5. BEI DATA MODEL****B.6. BEI ENTITY AND ATTRIBUTE DESCRIPTIONS****B.7. OUTSTANDING BEI BUSINESS ISSUES**

There are a number of outstanding business issues which will be resolved at the start of the Design phase of this document. These includes the Outstanding Questions noted against Entities in this document. Also included are:

| <b>Issue</b> | <b>Description</b>                                         | <b>Champion</b> |
|--------------|------------------------------------------------------------|-----------------|
| Issue #34    | Append Project Number or Ecosection Unit to Tag-id?        | Working Group   |
| Issue #35    | Remove non-labelled lakes from coverage?                   | Larry Lacelle   |
| Issue # 36   | Technical Standards Document body generic or Arc specific. | Working Group   |
| Logical ERD  | Hierarchical relationship questions                        | Working Group   |