

PART D
SOIL AND SEDIMENT SAMPLING

©Her Majesty the Queen in
Right of the Province of British Columbia
2003
All Rights Reserved

COMPOSTED MATERIALS SAMPLING

©Her Majesty the Queen in
Right of the Province of British Columbia
2003
All Rights Reserved

1. Introduction

This document sets out the sampling requirements for composted material, specified under terms of the

PRODUCTION AND USE OF COMPOST REGULATION

B.C. Reg.334/93 Deposited September 30, 1993.

2. Sampling and Analysis Requirements

The compost product must be sampled and analyzed as follows:

A sample of compost produced at each composting facility must be analyzed at intervals of at least every 1000 tonnes of compost produced or once in 3 months, whichever comes first, for:

<u>Parameter</u>	<u>Unit</u>
Total Nitrogen	% dry weight
Total Phosphorus	% dry weight
Total Potassium	% dry weight
Organic Matter	% dry weight
Salinity (EC)	mS cm ⁻¹
pH	(does not have units)
Foreign Matter	%
Arsenic	mg/kg dry weight
Cadmium	mg/kg dry weight
Chromium	mg/kg dry weight
Cobalt	mg/kg dry weight
Copper	mg/kg dry weight
Lead	mg/kg dry weight
Mercury	mg/kg dry weight
Molybdenum	mg/kg dry weight
Nickel	mg/kg dry weight
Selenium	mg/kg dry weight
Zinc	mg/kg dry weight

3. Trace Elements

Heavy metal concentrations, expressed in mg/kg dry weight, determine the appropriate use classification code; if any one parameter falls in a higher concentration grouping, the code for that higher grouping will apply.

3.1 Trace Element Concentration Codes

	<u>1</u>	<u>2</u>	<u>3</u>	<u>4</u>
Arsenic	<13	>13-30	>30-50	>50
Cadmium	<2.6	>2.6-5	>5-20	>20
Chromium	<210	>210-250	>250-800	>800
Cobalt	<26	>26-50	>50-300	>300
Copper	<100	<100	>100-500	>500
Lead	<150	>150-500	>500-1000	>1000
Mercury	<0.8	>0.8-2	>2-10	>10
Molybdenum	<5	>5-10	>10-40	>40
Nickel	<50	>50-100	>100-500	>500
Selenium	<2	>2-3	>3-10	>10
Zinc	<315	>315-500	>500-1500	>1500

4. pH

The pH must range between 5.0 and 8.0

5. Sampling Procedures

A single composite sample needs to be representative of the compost being tested.

- At least 5 to 10 samples should be taken from different locations around the pile.
- Samples should be taken from a depth greater than 25 cm and not more than 1 metre.
- Composite samples must be thoroughly mixed in a large container to provide a representative sample of the pile.

Laboratory staff should be consulted to determine the amount of compost required to carry out analyses.

6. Product Maturity

Mature means material that is highly stabilized, has been exposed to a long period of decomposition, is brown to black in colour, and

- will not reheat upon standing to greater than 20 degrees C above ambient temperature, or
- has shown a reduction of organic matter of greater than 60% by weight.

The regulation requires that a measure of product maturity be determined. Two alternative methods are acceptable under this regulation as the measurement procedure.

6.1 Reheating Test

A reheating test can be used to measure stability. Compost should be re-piled so it is at least 2 meters in diameter and 1.5 metres high. The pile should not be compressed and should be loose enough to allow the penetration of air. Moisture content of the pile should be somewhere between 35% and 60%. A dry pile will give the false impression that the compost is mature. Three days later the temperature of the compost should be measured at a point 60 cm into the pile. A comparison of this temperature with ambient air temperature gives a picture of the product maturity.

6.2 Ratio Between Organic Solids and Mineral Solids

Reduction of organic matter content during the composting process increases the percentage of mineral solids present. This ratio between organic solids and mineral solids present provides a picture of how close to maturity a compost product is. Before and after composting the material is tested for the percent organic matter (volatile solids) on a dry weight basis. The calculation is:

$$\% \text{ Reduction} = \left[1 - \frac{\%A (100 - \%B)}{\%B (100 - \%A)} \right] \times 100$$

where %A = % organic matter content of dry matter after decomposition,
 and
 %B = % organic matter content of dry matter before
 decomposition.

“Loss on ignition analysis” is used to determine the percentage organic matter content before and after decomposition. During composting the ratio of organic matter to inorganic matter changes due to decomposition and the mass of inorganic solids remains the same. Using this formula it is possible to calculate the percentage "reduction of organic matter content" in the final product necessary to meet the required level of reduction for compost classified as mature or fresh.

7. Foreign Matter Content

Foreign matter content may be determined by passing a dried, weighed sample of the compost product through a 6 mm screen. The material remaining on the screen is visually inspected, and the foreign matter that can be clearly identified is separated and weighed. The weight of the separated foreign matter divided by the weight of the total sample multiplied by 100 is the percentage dry weight of the foreign matter content.

Foreign matter content by dry weight must be classified within one of the following categories before being utilized on land:

- (i) 1%
- (ii) >1% but ≤ 2%
- (iii) >2% but ≤ 10%

8. Revision History

February 28, 2001: This section has been republished without change.

LAKE AND STREAM BOTTOM SEDIMENT SAMPLING

©Her Majesty the Queen in
Right of the Province of British Columbia
2003
All Rights Reserved

Table of Contents

1. INTRODUCTION	189
2. GENERAL CONSIDERATIONS	190
2.1 Preparing to Go to the Field	190
2.2 Locating the Site in the Field	190
2.3 Field Notes/Observations	191
3. QUALITY ASSURANCE/QUALITY CONTROL	191
3.1 Field Quality Assurance	191
3.2 Field Quality Control	192
3.2.1 Replicate Samples	193
3.2.2 Reference Samples	193
4. SAMPLING EQUIPMENT	193
4.1 Grab Samplers	194
4.1.1 Ekman Grab	195
4.1.2 Petersen Grab	195
4.1.3 Ponar Grab	196
4.2 Core Samplers	196
4.3 Sediment Particle Size Samplers	198
5. COLLECTING SEDIMENT SAMPLES	199
5.1 Collecting Lake Sediment Samples	199
5.1.1 Sampling from a Boat	199
5.1.2 Winter Sampling	202
5.2 River/Stream	203
5.2.1 Access from a bridge	203
5.2.2 Sampling from a Boat	205
5.2.3 Winter Sampling	205
5.2.4 Sampling for Sediment Particle Size	206
6. SHIPPING	207
7. SOURCES OF FURTHER INFORMATION	208
8. REVISION HISTORY	209
APPENDIX 1 GENERIC FIELD CHECKLIST	210
APPENDIX 2 LAB SAMPLE CONTAINER, PRESERVATION, AND HOLD TIMES FOR SEDIMENTS AND TISSUES	212

1. Introduction

This section covers the minimum requirements to ensure quality and consistency of the field aspects of lake and stream bottom sediment data collection. Sediments collected using the techniques outlined here will be analyzed for sediment chemistry and for physical characteristics such as particle size distribution. The essential tasks in sediment sampling are to collect representative, undisturbed samples that meet the requirements of the program, and to prevent deterioration and contamination of the samples before analyses. The procedures outlined in this manual are oriented primarily towards Ministry of Water, Land and Air Protection employees, consultants, or those under a legal requirement to undertake a sampling program for the Ministry. Following the protocols outlined in this section will aid field staff in collecting reliable, representative samples.

The protocols presented here are the most acceptable ones used at present. It should be emphasized that in unusual circumstances, or with development of new methods, experienced professional judgment is a necessary component of method choice and application. It is intended that this document will be updated as the need arises to reflect new knowledge.

This section does not address the collection of samples for the purpose of providing legal evidence. For information regarding legal sampling, refer to *Guidelines for the Collection and Analyses of Water and Wastewater Samples for Legal Evidence* (Lynch and van Aggelen, 1993).

This section does not address project design (site locations, frequency of sampling, duration, laboratory quality assurance program, etc.) or data interpretation. These topics are the subject of separate sections or other documents.

The sample containers, preservatives and sampling procedures described in this manual reflect those most widely used by Ministry of Water, Land and Air Protection. Shipping procedures and safety measures are also outlined. Different agencies or laboratories may have specifications that differ from those described here.

It should be acknowledged that funding for the initial manuscript upon which this section is based was provided by the Aquatic Inventory Task Group of the Resource Inventory Committee.

2. General Considerations

2.1 Preparing to Go to the Field

Preparation for each sampling trip is critical since oversights are not usually noticed until staff reach the first station. The most effective way to prepare for a sampling trip is with a **checklist** that is designed to meet the requirements of each project. Other than considering site-specific instructions, the checklist should identify the following needs:

- Type and number of (labelled) bottles and containers, including extras
- Field equipment such as meters (with adequate trouble-shooting equipment for small repairs), sampling tools (sediment grabs, corers), etc.
- Preservatives
- Appropriate quantity of ice packs and coolers
- Logbooks
- Personal gear (for all possible weather conditions, e.g., survival suits, raincoats, protective footwear, etc.)
- First aid kit and other safety equipment (life jackets, survival suits)
- A section on the working status of equipment (i.e., properly loaded to avoid damage during transport, batteries charged, probes not damaged or dried, etc.)
- Camera or video equipment as required
- Laboratory requisition forms (partially filled out)

A general operating procedure is to have the key equipment in a box or plastic “tote” that is dedicated to this activity. See Appendix 1 of this chapter for an example of a generic checklist.

2.2 Locating the Site in the Field

It is the responsibility of the field staff to locate all sampling stations accurately. Only if the same location is consistently sampled can temporal changes in the sediment quality be interpreted with confidence. Therefore, accurately written station location descriptions (that identify key landmarks) must be prepared on the first visit to every sampling site. Good photographic documentation is the best way of ensuring that each site is easily recognized. A map that labels the sample sites should accompany the **site identification logbook**. This logbook can be in the form of a 3-ring binder with a 1:50 000 map. The basic site location data (latitudes, longitudes, map sheet number, site identification number, etc.) should be incorporated into the database (EMS in the case of Ministry of Water, Land and Air Protection).

2.3 Field Notes/Observations

Good sampling practice always involves the use of detailed field notes. Specific information about seemingly unimportant facts, such as the time of day or weather conditions, is often important when interpreting data. A **field logbook** (3-ring binder with water proof paper) for each project is mandatory. All field measurements should be entered (by date) directly into this field logbook. The following list emphasizes those observations that should be recorded:

- Site name and EMS code
- Date and time
- Station depth
- Names of all personnel on sampling crew
- Gross characteristics of sediment
 - Texture
 - Colour
 - Biological structure (e.g., shells, tubes, macrophytes)
 - Debris (e.g., wood chips, plant fibers)
 - Presence of oily sheen
 - Obvious odour
- Gross characteristics of vertical profile (distinct layers, depth of layer changes)
- Penetration depth of sediment sampler

All information recorded in the logbook should be entered into the database as soon as possible upon return from the field.

3. Quality Assurance/Quality Control

3.1 Field Quality Assurance

The field quality assurance program is a systematic process that, together with the laboratory and data storage quality assurance programs, ensures a specified degree of confidence in the data collected for an environmental survey. The field quality assurance program involves a series of steps, procedures, and practices that are described below.

The quality of data generated in a laboratory depends, to a large degree, on the integrity of the samples that arrive at the laboratory. Consequently, the field investigator must take the necessary precautions to protect samples from contamination and deterioration.

There are many sources of contamination; the following are some basic precautions to consider:

- Sample containers, new or used, must be cleaned according to the recommended methods and certified by the issuing laboratory as 'contamination free' (if pre-cleaned by the laboratory).
- Only the recommended type of sample container for each analysis should be used (Appendix 2 of this chapter).
- The inner portion of sample container and caps must not be touched with anything (e.g., bare hands, gloves, etc.) other than the sample itself.
- Sample containers must be kept in a clean environment, away from dust, dirt, fumes and grime. Containers must be capped at all times and stored in clean shipping containers (coolers) both before and after the collection of the sample. Vehicle cleanliness is an important factor in eliminating contamination problems.
- Petroleum products (gasoline, oil, exhaust fumes) are prime sources of contamination. Spills or drippings (that are apt to occur in boats) must be removed immediately. Exhaust fumes and cigarette smoke can contaminate samples with lead and other heavy metals. Air conditioning units are also a source of trace metal contamination.
- Samples must never be permitted to get warm; they should be stored in a cool place; coolers packed with ice packs are recommended (most samples must be cooled to 4°C during transit to the laboratory). Conversely, samples must not be permitted to freeze unless freezing is part of the preservation protocol (see Appendix 2 of this chapter).
- The sample collectors should keep their hands clean and refrain from smoking or eating while working with samples.

3.2 Field Quality Control

Quality control is an essential element of a field quality assurance program. In addition to standardized field procedures, field quality control requires the submission of replicate and reference samples. Replicate samples detect heterogeneity within the environment, allow the precision of the measurement process to be estimated, and provide a check that the sample is reproducible.

Reference samples are used primarily to document the bias of the analytical (laboratory) process, however, any influence or contamination introduced during sample preparation, handling, or during lab analysis will be reflected. The timing and the frequency of replicate and reference samples are established in the project design and will vary with each project.

3.2.1 Replicate Samples

To determine the degree of heterogeneity within the sediments, it is necessary to take replicate samples. These replicates can consist of multiple samples (grabs) from the same general area (to measure site heterogeneity), or portions of a single grab (to measure more localized heterogeneity). Grab samples that are homogenized (physically stirred) in the field and then sub-sampled into replicates serve as a tool to estimate the analytical (laboratory) precision. Refer to section 5.1 for the protocol to collect the samples.

3.2.2 Reference Samples

Laboratory tested and preserved reference sediment samples have been prepared and certified by a national, international or standards agency such as the National Research Council of Canada. These reference samples have been subjected to a large number of analyses performed by independent laboratories using several different analytical techniques. Consequently, the laboratory supplying the reference material provides mean values and confidence intervals for these substances.

These reference samples should be submitted to the analyzing laboratory along with the samples collected during a field trip. Reference sediment samples are distributed as a dry dust, therefore, the analyzing laboratory will be aware that they are reference samples. Nevertheless, they should be transferred to a regular, coded sample container so the lab does not know which reference sample it is dealing with.

4. Sampling Equipment

Generally, there are two types of samplers used for collecting bottom sediments: (1) grab samplers for collecting surface sediments, thereby providing material for the determination of horizontal distribution of variables; and (2) core samplers for collecting a depth profile of sediments, thereby providing material for determination of vertical distribution of variables. Grab samplers, due to their ease of use and large quantity of sample obtained, are ideal for assessing recent inputs of pollutants. The core samplers are better suited for assessing long-term (historical) inputs. The type of sampler used at particular sites will vary depending on the purpose of the study and will be dictated by the project design.

4.1 Grab Samplers

Simplified drawings of grab samplers with their essential components are shown in Figure 1. The grab samplers commonly used by Ministry of Water, Land and Air Protection are of designs that use a set of jaws that shut when lowered to the sediment. In the case of the Ekman and Ponar grabs, vented or hinged tops allow water to flow freely through the device during descent, thereby reducing sediment disturbance that would otherwise be created by a shock wave in front of the sampler. The advantages associated with these grab samplers are that they are easy to use and obtain relatively large volumes of sediment. A disadvantage is that upon retrieval, fine surface particulates can be carried away by outflowing water. Several designs, other than those illustrated or mentioned here for sediment samples, are available and may be appropriate in certain conditions. Other designs include the mini-Ponar and the Van Veen.

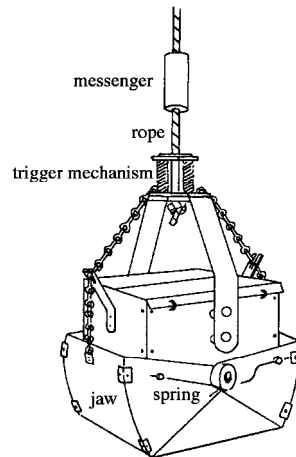

Ekman grab

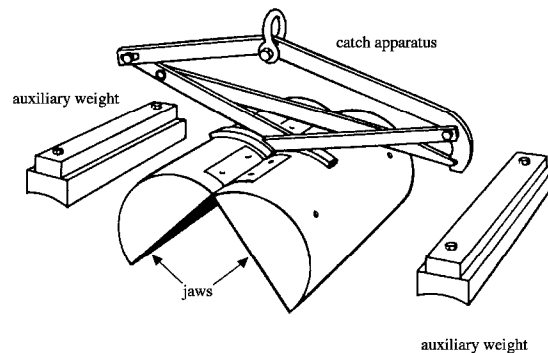

Petersen Grab

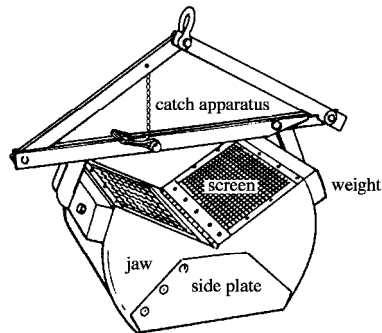

Ponar grab

Figure 1. Common Sediment Grab Samplers

4.1.1 Ekman Grab

Ekman grabs are variable in size with larger models requiring the use of a winch or crane hoist for operation. Typically the 15 x 15 cm size is used. These have historically been fabricated in brass, but stainless steel is now used and is more desirable (fewer problems with corrosion and less likelihood of effecting metal concentrations in sediment sample). The spring-tensioned, scoop-like jaws are mounted on pivot points and are set with a trigger assembly that is activated from the surface by a messenger. Flaps on the top of the grab open during descent to allow water to flow freely through, then close during ascent to reduce loss of sample during retrieval. The sediment can either be sub-sampled through the top flaps or can be dumped into a tray and treated as a bulk sample. The Ekman sampler is suitable for collecting soft, fine-grained sediments (silt and sand). Larger substrate particles (i.e., gravel) and objects such as shells and wood tend to prevent the jaws from fully closing that results in loss of sample material.

NOTE: If the jaws are not fully closed, then the sample must be discarded.

4.1.2 Petersen Grab

The Petersen grab consists of a pair of weighted semi-cylindrical jaws that are held open by a catch bar. Upon impact with the sediment (slackening of the rope), the tension on the catch bar is reduced allowing the jaws to close. Auxiliary weights can be added to the jaws to improve penetration into harder, more compacted sediments. There is no access to the sample through the top of the grab, consequently the sediments must be dumped into a tray and treated as a bulk sample. The Petersen grab is suited to the collection of hard bottom material such as sand, marl, gravel, and firm clay.

4.1.3 Ponar Grab

The Ponar grab consists of a pair of weighted, tapered jaws that are held open by a catch bar. It is triggered to close in much the same fashion as the Petersen grab. The upper portion of the jaws is covered with a mesh screen that allows water to flow freely during descent, consequently reducing the shock wave that precedes the sampler. Upon recovery, the mesh can be removed to allow access to the sediment for sub-sampling purposes. The Ponar grab is suitable for collecting fine-grained to coarse material.

4.2 Core Samplers

Core samplers penetrate the sediment more deeply than grab samplers. Consequently, they provide a cross-sectional slice of sediment layers and thus, information about the sediment deposition. The core samplers commonly used by Ministry of Water, Land and Air Protection consist of a tube that enters the sediment by free falling from a sufficient height (usually 3-5 metres). Alternatively, in soft organic sediments, the weight of the core sampler is sufficient to fully penetrate the sediments without allowing it to free fall. A valve at the top of the sampler closes by messenger, creating a vacuum seal that prevents the sediments from washing out. The most common core sampler used by Ministry of Water, Land and Air Protection is the Kajak-Brinkhurst sampler (Figure 2). Variations on this design are available from several commercial suppliers.

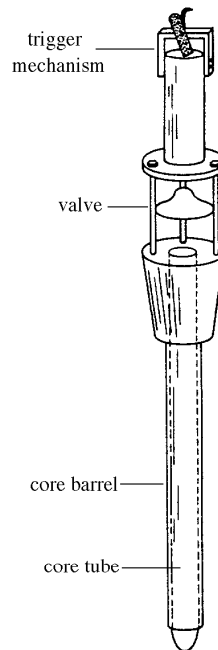

Figure 2. Kajak-Brinkhurst Sediment Core Sampler

4.3 Sediment Particle Size Samplers

Although the previously mentioned samplers can be used for the purpose of determining the distribution of streambed particle sizes, they are not ideal. Much of the very fine sediments are lost because of the pressure wave that precedes these samplers, and washout as the samplers are retrieved. Better estimates of particle size distribution can be obtained through the use of sediment traps (over a prescribed time frame), or samplers that collect an entire portion of the streambed (i.e., McNeil sampler and Freeze core sampler). The freeze core sampling technique is elaborate and cumbersome; consequently, it will not be discussed here. Detailed descriptions of the use of this piece of equipment can be obtained from Ryan (1970) and Sookachoff (1974).

Sediment traps are simply open buckets of a given volume that are filled with cleaned gravel and immersed in the streambed. They are collected at a later date and submitted for mechanical analysis of sediment particle size.

The McNeil sampler (Figure 3) consists of a cylinder that defines the portion of the streambed to be sampled and an attached basin that is used to store the collected sediments and trap the suspended fines.

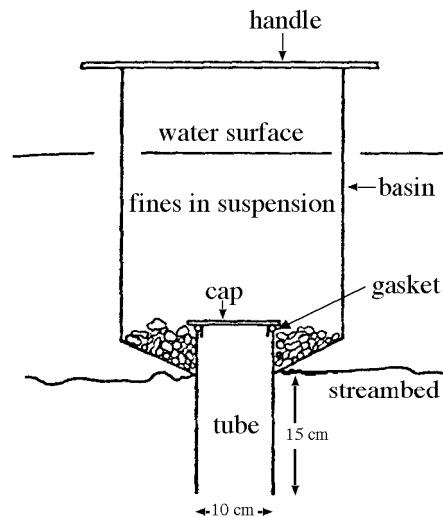

Figure 3. McNeil sediment size sampler

5. Collecting Sediment Samples

Sediment samples are collected for either analysis of chemical and physical properties of the sediment, or to assess the benthic biotic community structure (biomass and/or taxonomy). A number of basic requirements must be met to obtain representative sediment samples:

- The sampling device must penetrate the sediment to a sufficient depth to measure the variables of concern accurately.
- The sampling device must enclose the same quantity of sediment each time.
- The sampling device must close completely each time.
- Care should be taken not to disturb the sediments prior to deployment of the sampling device.

Note: Since sediment samplers disturb overlying waters they should be used only after the ambient water sampling has been completed at the site.

5.1 Collecting Lake Sediment Samples

Regardless of the equipment chosen for the sample collection, it is necessary to know the water depth at each station before starting. If water depth information is unavailable, it is recommended that it first be measured. Measurement equipment can range from a weighted rope to an electronic depth sounder. The purpose is to ensure adequate cable (rope) length for operation of the equipment and to control the speed of entry of the sampler into the sediment. The speed of deployment of the sampler can be critical to good operation and sample recovery. Too rapid deployment generates and increases the shock wave advancing in front of the equipment. This shock wave can displace the soft unconsolidated surface sediments. Rapid deployment may also cause equipment malfunction, such as activating the trigger mechanism before the device reaches the sediment. In the case of core samplers, if the deployment is too slow, an insufficient quantity of sediment is obtained. Since the site-specific conditions will dictate the speed of sampler deployment, the specifics should be recorded in the field logbook (i.e., the height from which the corer was allowed to free fall).

5.1.1 Sampling from a Boat

The collection of deep water samples requires that at least one member of the sampling group be very familiar with boat operation and safety. **If the sampling trip involves the use of a boat, then the weather forecast or marine conditions should be obtained prior to departure from home. If conditions are poor, then the sampling trip should be postponed.**

PROTOCOL

(sampling from a boat with a grab sampler)

- (a) Set the grab sampling device with the jaws cocked open (see Figure 1). **Great care should be taken while handling the device while it is set; accidental closure can cause serious injuries.**
- (b) Ensure that the rope is securely fastened to the sampler and that the other end is tied to the boat.
- (c) Lower the sampler until it is resting on the sediment (its own weight is adequate to penetrate soft sediments). At this point the slackening of the line activates the mechanism to close the jaws of the Ponar and Petersen grabs.
- (d) For the Ekman grab, send the messenger down to 'trip' the release mechanism.
- (e) Retrieve the sampler slowly to minimize the effect of turbulence (that might result in loss/disturbance of surface sediments).
- (f) Place a container (i.e., a shallow pan) beneath the sampler just as it breaks the surface of the water.

Note: If the jaws were not closed completely, the sample must be discarded. Discard the sample into a bucket if the second collection attempt is made from the same general area. Dump the unwanted sample only after a sample has been successfully collected.

For replicate samples, proceed with instruction (g). For non-replicate samples proceed from instruction (h).

- (g) If the sample is to be split into replicates (Ekman or Ponar grabs), then open the top flaps and carefully divide the sample into the required number of replicates with a clean spatula. Scoop the replicates into pre-labelled bottles and store in a cooler. **A selection can be made of the surface sediments (1 - 2 cm) by carefully scooping off the top undisturbed layers. In some lakes, a grab sample to a depth of 10 - 15 cm is typical and the vertical heterogeneity may represent many years of lake or watershed changes.**

Note: For samples that are to be analyzed for organics, the spatula and container must not be plastic (the container must be a glass bottle provided by the laboratory). For samples to be analyzed for metals, the spatula must not be metallic.

- (h) For sediments that are to be treated as bulk samples (one large sample), gently open the jaws and allow the sediments to empty into the container (shallow pan).
- (i) Immediately record (in the field logbook) observations regarding the appearance of the sediment (i.e., texture, colour, odour, presence of biota, presence of detritus, and the depth of sediment sampled).
- (j) With a clean spatula, carefully stir the sediment to homogenize, and then scoop an aliquot into a pre-labelled sediment sample bottle (see Appendix 2 for appropriate container).
- (k) Place the samples in a cooler with ice packs as soon as they are transferred to the bottles.

Note: Many lake sediment samples are anoxic and a number of chemical changes will take place if the samples are exposed to atmospheric oxygen. If samples are to be retained with as low oxygen as possible, they will need to be packed inside multiple airtight containers and frozen to minimize the chemical and microbial transformations. Be warned that it may still have a strong odour even if sealed and frozen! If samples are frozen, allow sufficient head space for expansion of the sample. Otherwise, the container will split or break when the sample freezes.

PROTOCOL

(sampling from a boat with a core sampler)

- (a) Open the valve and set the trigger mechanism (Figure 2). Ensure the rope is securely fastened to the corer and attach the other end of the rope to the boat.
- (b) Lower the corer to approximately 5 m above an area of undisturbed sediments and then allow it to fall freely into the sediments (drop depth may vary with sampler size, weight, and sediment type). Sufficiently heavy corers can be simply lowered into the sediments to avoid the disturbance caused by impact.
- (c) Send the messenger down to release the trigger mechanism.
- (d) Carefully retrieve the sampler and place a stopper into the bottom opening **before** removing from the water to prevent loss of the sample.
- (e) Remove the liner from the corer and stopper the upper end. Store erect. Repeat this procedure to obtain replicate cores, each at least 0.5 m in length.

- (f) Once on shore, carefully siphon off most of the water overlying the sediments in the core tube (leave a small amount at the sediment-water interface). **Do not disturb the sediment-water interface.**
- (g) Make careful measurements of the total length of the core and precise points (nearest mm) of any layers of sediment that appear to be different. Note any changes in stratigraphy, such as colour and texture.
- (h) A rubber stopper of a size sufficient to fit inside the liner tube tightly to form a watertight seal and mounted on a rod is inserted into the lower end. The core is then **gently** and **slowly** forced upward to the top of the tube. Some advanced corers come equipped with this stopper and the increment of each sediment slice can be adjusted.
- (i) As the sediment core is extruded, carefully cut slices (one cm or more thick) with **clean** spatulas and place into labelled sample bottles. A core slicer greatly assists this operation, but good samples can be obtained without this aid when done carefully.

Note: For samples that are to be analyzed for organics, the spatula and container must not be plastic (the container must be glass bottles provided by the laboratory). For samples that are to be analyzed for metals, the spatula must not be metallic.

- (j) Place the samples in a cooler with ice packs as soon as they are transferred to the labelled bottles.

5.1.2 Winter Sampling

Sampling in winter presents extra elements of danger. **Always proceed with caution over ice and do not jeopardize your safety.** Check the ice for thickness with a rod or ice chisel every few steps (ice should be a minimum of 8 cm thick). **Always have someone follow you, and carry a length of rope (with a harness tied around your waist) to use as a life line. If the ice is unsafe, do not take a sample. Never take unnecessary risks.**

Note: Ice near the outlet of a lake is often thin; therefore, caution should be used when sampling this area of a lake. Ice may also be thin where a stream enters a lake or where groundwater enters a lake.

PROTOCOL

(for sampling through ice)

- (a) **With safety considerations in mind**, winter sampling locations should be as close as possible to the summer locations. The sites should be chosen where the water is known to be deep enough to avoid stirring up bottom sediments while drilling the hole.
- (b) Clear loose ice and snow from the sampling location, and drill through the ice with a hand or motorized auger. Keep the area around the hole clear of potential contamination (dirt, fuel, oil, etc.). **At least one member of the sampling team should be familiar with the operation and safety of both motorized and hand operated augers.**
- (c) Follow sample collection procedures outlined above for either grab or core samplers (section 5.1.1 - sampling from a boat).

5.2 River/Stream

Sediment sampling in deep sections of rivers and streams rarely involves the use of core samplers as these devices require that flow be minimal (very few rivers worldwide have sufficiently low flow). Alternatively, core samples can be collected in shallow, flowing waters by physically pushing the corer into the sediment by hand.

It is useful to have some understanding of the currents at the sampling site. Strong near-bottom currents can lead to poor equipment deployment, deflect a grab sampler, or require a long cable/wire to be deployed. Care should be taken to ensure that the weight of the sampler is adequate for working in the particular current conditions and that the sampler collects sediment at or very near the desired sampling site.

5.2.1 Access from a bridge

Some sample stations are designed to be sampled from a bridge. Consequently, samples can be collected from the center of the channel without the use of a boat.

PROTOCOL

(from bridge with a grab sampler)

- (a) Set the grab sampling device with the jaws cocked open (see Figure 1). **Great care should be taken while dealing with the device while it is set; accidental closure could cause serious injuries.**
- (b) Ensure that the rope is securely fastened to the sampler and that the other end of the rope is tied to the bridge.

- (c) Lower the sampler over the upstream side of the bridge until it is resting on the sediment (its own weight is adequate to penetrate soft sediments). At this point the slackening of the line activates the mechanism that releases the jaws of the Ponar and Petersen grabs.
- (d) For the Ekman grab, send the messenger down to 'trip' the release mechanism.
- (e) Retrieve the sampler slowly to minimize the effect of turbulence that might result in loss of surface sediments.
- (f) Place a container (i.e., a shallow pan) beneath the sampler as soon as it is on the bridge.

Note: If the jaws were not closed completely, the sample must be discarded (over the downstream side of the bridge or on shore if sensitive water uses exist immediately down stream. Dump the unwanted sample only after a sample has been successfully collected.

- (g) If replicates are to be collected, then refer to Section 5.1.1 steps (g) and (h). Otherwise, for a bulk sample, gently open the jaws and allow the sediments to empty into the container.
- (h) Immediately record, in the field logbook, observations regarding the appearance of the sediment (i.e., texture, colour, odour, presence of biota, presence of detritus, and the depth of sediment sampled).
- (i) With a clean spatula either remove the top portion of the sediment (when this is outlined by the study design), or carefully stir the sediment to homogenize. Place an aliquot into a pre-labelled sediment sample bottle.

Note: For samples to be analyzed for organics, the spatula and container must not be plastic. The container must be a glass bottle provided by the laboratory. For samples to be analyzed for metals, the spatula must not be metallic.

- (j) Place the samples in a cooler with ice packs as soon as they are transferred to the bottles.

5.2.2 Sampling from a Boat

Due to the fact that fast-flowing waters pose a serious threat, it is essential that the person operating the boat be very experienced with river boating. Ideally there should be three people involved in the sampling trip when it involves boating on a river. Two people are responsible for collecting the samples, taking field measurements and recording field notes. The remaining person is responsible for boat operation only.

Sampling trips should start at the site that is most downstream and work upstream. If mechanical problems should arise, then the current will work to your advantage and assist you to return to the vehicle.

PROTOCOL (in flowing waters)

- (a) When a sample site is reached, the boat operator will idle into the current so as to maintain the boat in one location. Use reference points on shore to do this.
- (b) The person in the bow is responsible for collecting the samples (water column samples before sediment samples).
- (c) Collect the sediment with a grab sampler as outlined in the lake sampling section (5.1.1).

5.2.3 Winter Sampling

Due to the fact that flow patterns in rivers and streams are generally more complex than in lakes, there are additional safety factors to consider. Honeycombed ice and areas over rapids should always be avoided. Be aware that ice downstream from bridge supports may be thin as a result of modified flow patterns and de-icing agents.

Generally, winter sampling on rivers follows a similar protocol to sampling lakes in winter. The primary exception occurs when the ice is unsafe; when this is the case, sample stations that are accessible from a bridge are the only option.

PROTOCOL

(for sampling when ice is safe)

- (a) **With safety considerations in mind**, winter sampling locations should be as close as possible to the summer locations. The sites should be chosen where the water is known to be deep enough to avoid stirring up bottom sediments while drilling the hole and to ensure that there is water movement under the ice at the selected spot.
- (b) Clear loose ice and snow from the sampling location, and drill through the ice with a hand or motorized auger. Keep the area around the hole clear of potential contamination (e.g., dirt, fuel, oil, etc.). **At least one member of the sampling team should be familiar with the operation and safety of both motorized and hand operated augers.**
- (c) Follow procedures outlined above (section 5.1.1).

5.2.4 Sampling for Sediment Particle Size

PROTOCOL

(McNeil sampler)

- (a) Wade into the water downstream of the intended sample collection site.
- (b) Remove the cap from the sampling tube (see Figure 3). Ensure that you are in sufficiently shallow water that the sampler will not be swamped when the tube portion is inserted in the sediment.
- (c) Thrust the sampler through the water column and force the tube into the sediment until the bottom of the collecting cylinder is on the streambed.
- (d) Reach in and remove all the streambed material that is in the tube.
- (e) Recap the tube and carefully withdraw the sampler from the sediment. Return to shore and pour the contents of the sampler through a fine mesh sieve into a collecting pan.
- (f) Transfer the water from the pan to a pre-labelled bottle. This bottle can either be submitted for total suspended sediment analysis (non-filterable residue), or to a pre-determined lab for hydrometric particle size analysis (the Ministry of Agriculture, Food and Fisheries or the Ministry of Highways have the capability to conduct this sort of analysis). The larger materials that were trapped in the sieve must be submitted to one of the facilities capable of mechanical analysis for size. These can be transported in well-labelled heavy-duty plastic bags.

PROTOCOL
(sediment traps)

- (a) Prior to the sampling trip, gravel of fairly uniform size should be collected and cleaned. Place the gravel in four litre buckets (fill each bucket to the rim). Replace the lids.
- (c) Once in the field, dig a hole in the streambed large enough that the bucket will be immersed in the sediment to the point that the top will be flush with the streambed. Wait until the disturbed fine sediments have cleared before you place the bucket in the hole.
- (d) While the lid is still on, gently place the bucket in the hole and surround it with streambed material until it is secure. Once again, wait until disturbed materials have cleared before removing the lid.
- (e) **Note: Never walk upstream of the buckets as this will disturb sediments that will be captured in the sediment trap.**
- (d) After the time outlined by the project design (usually 2 - 4 weeks), gently replace the lid and remove the bucket from the streambed.
- (e) Submit the bucket(s) to a pre-determined lab for mechanical (particle size) analysis (the Department of Agriculture Food and Fisheries or the Ministry of Highways have facilities that conduct this sort of analysis).

6. Shipping

The day's sampling schedule must be designed to ensure that the samples arrive at the shipping agency's terminal well before the end of business hours. Since some variables have very limited hold times (see Appendix 2), every effort must be made to avoid delays in shipping. The following is the procedure to be followed to maintain the integrity of the samples during transit.

PROTOCOL
(shipping)

Note: Ice packs should be used instead of loose ice or bagged ice. When loose ice melts, the contents of the cooler are free to shift, potentially allowing contamination of samples with melted ice water and/or breakage of glass bottles.

- (a) Pack the samples upright in the cooler with at least 1 (winter) to 2 (spring, summer, fall) times as much ice packs as the total volume of the samples. Ensure that the glass bottles are separated from each other by ice packs, plastic bottles or clean packing material to prevent them from shifting, falling over and/or breaking.
- (b) Complete the laboratory requisition forms, enclose them in a sealed plastic bag, and place them in the cooler on top of the samples. The recommended minimum information that should accompany samples to the laboratory (on each requisition form) includes:
- Site name
 - EMS site numbers
 - Date and time of collection
 - Name of collector
 - Field measurements
 - Comments on sample appearance
 - Weather conditions
 - Any other observations that may assist in interpreting data.
- (c) Seal the cooler with heavy duty packing tape to reduce the possibility of it accidentally opening and to prevent tampering with the samples. Coolers arriving at the laboratory with torn or absent tape should be noted by lab staff and the sample submitter notified.
- (d) Attach a label prominently displaying the destination.

7. Sources of Further Information

American Public Health Association, American Water Works Association, Water Environment Federation. 1992. Standard Methods for the Examination of Water and Wastewater. 18th edition. *Edited by:* Greenberg, A.E., Clesceri, L.S., Eaton, A.D., and Franson, M.A.H. *Published By:* American Public Health Association.

Clark, M.J.R., Shera, W.P. (*Editors*). 1985. Methods for Aquatic Data Collection in British Columbia: A Catalogue. BC Ministry of Environment, Victoria, B.C.

Environment Canada. 1983. Sampling for Water Quality. Water Quality Branch, Inland Waters Directorate, Ottawa.

McNeil, W.J., and Ahnell, W.H. 1964. Success of Pink Salmon Spawning Relative to Size of Spawning Bed Materials. United States Fish and Wildlife Service. Special Scientific Report, Fisheries No. 469. Washington, District of Columbia. 15pp.

Mudroch, A., and MacKnight, S. 1991. Handbook of aquatic sediment sampling. CRC Press Inc.

Ryan, P. 1970. Design and Operation of an In Situ Frozen Core Gravel Sampler. Technical Report No. 1970 - 12. Environment Canada. Department of Fisheries and Forestry, Fisheries Service, Pacific Region.

Sookachoff, P. 1974. The Modified In Situ Frozen Core Gravel Sampler. Technical Report Series No. PAC/T - 74-16. Environment Canada. Fisheries and Marine Service Habitat Protection Unit, Southern Operations Branch, Pacific Region.

Wetzel, R.G., and Likens, G.E. 1991. Limnological Analysis. Second edition. Springer - Verlag, New York.

8. Revision History

February 28, 2001: This section republished without change. Note added to Appendix 2 requiring glass or Teflon™ containers for samples to be analyzed for mercury.

November 1996: Initial publication.

Appendix 1 **Generic Field Checklist** (including water, sediments, biota and effluents)

General:

Logbooks _____	Pencils _____
Cooler (with ice packs) _____	Felt Markers (waterproof) _____
Rope _____	Tape _____
Camera (film) _____	Requisition forms _____
Waybills _____	Shipping labels _____
De-ionized water (4L) _____	Squirt bottle _____
Resealable bags _____	

Labelled Sample Bottles:

General chemistry (1 L) # _____	General chemistry (2 L) # _____
Dissolved Metals # _____	Total Metals # _____
Total Organic Carbon # _____	Low-level nutrients # _____
Coliforms # _____	Sediments # _____
Zooplankton # _____	Phytoplankton # _____
Periphyton # _____	Invertebrates # _____
Tissue cups # _____	Macrophytes _____ +Extras - two of each

Sampling Equipment (clean, in working order, batteries charged):

DO Sampler (BOD bottle, Winkler reagents) _____	
Thermometer _____	DO meter _____
pH meter _____	Conductivity meter _____
Hydrolab _____	Secchi disc _____
Van Dorn, rope _____ messenger _____	Through Ice Sampler _____
Auger (bit sharpened, skimmer) _____	Spare probe membranes (repair kit) _____
Sediment grab _____ messenger _____	Sediment corer _____ sample tubes _____
Sieves _____	Zooplankton tow nets _____
Benthic invertebrate sampler (Hess, drift net, Surber) _____	
Periphyton kit (cup, denture brush, baster) _____	
Macrophyte sample kit (buckets, garbage bags, float tray, plant press, blot paper, herbarium sheets, newsprint, corrugated cardboard) _____	

Filtration and Preservation Equipment:

Filter Pots _____	Syringe(s), Hose _____
Tweezers _____	0.45 μ membrane filters _____
Preservative Vials _____	Disposal Container (for used vials) _____
70% ethanol _____	Formalin _____
Lugol's solution _____	Magnesium carbonate _____

Boat Equipment:

Canoe (or boat) _____	Paddles _____
Motor _____	Fuel _____
Life jackets _____	Ropes _____
Anchor _____	Tool kit _____

Lake & Stream Bottom Sediment Sampling

Personal Gear:

Lunch _____

Rain gear _____

Waders (hip, chest) _____

Flash light _____

Survival suit _____

Gum boots _____

Sun screen _____

Safety:

WHMIS guidelines _____

Goggles (or safety glasses) _____

First Aid Kit _____

Rubber gloves _____

Appendix 2 Lab Sample Container, Preservation, and Hold Times for Sediments and Tissues

<u>TYPE OF ANALYSIS</u>	<u>MINIMUM SIZE</u>	<u>CONTAINER TYPE</u>	<u>PRESERVATION</u>	<u>MAXIMUM HOLD TIME</u>
SEDIMENTS AND TISSUES				
General chemistry	200 g	P, W	keep cool, 4°C	72 h
EOX, Extractable Organic Halides	50 g	G, Solve, Fact	freeze (dry ice)	6 mo
Metals (not mercury)	100 g	P, W (T)	keep cool, 4°C	72 h
Organic Carbon	100 g	P or G	keep cool, 4°C	72 h
Organics - Semivolatile	200 g	G, A, W, Solve	freeze (dry ice)	6 mo
Organics - Volatile	50 g	G, W, Solve, B	freeze (dry ice)	14 d
Particle Size Analysis	100 g dry wt	P or G	keep cool, 4°C	72 h
PQ-8 (copper 8, copper equivocate)	100 g	G (A), W, Solve	freeze (dry ice)	6 mo
Mercury	100 g	G (A), TV, W/T	keep cool, 4°C	28 d

ANALYSES WITH LIMITED SHELF LIFE

PH, Turbidity, Acidity, Alkalinity	72 h
Ammonia, TKN, Nitrate, Nitrite	72 h
Phosphorus (Phosphate) Roth, total, total dissolved	72 h
Bacteria	48 h

LEGEND

P = plastic	G = glass	Tf = Teflon (™)
B = Baked	T = Tissue Cup	
Solv = solvent cleaned	A = amber	
Fc = foil lined cap	W = wide mouth	

These are general guidelines and different labs may have specific criteria.

***NOTE: glass or Teflon™ containers must be used if mercury is to be analyzed.**